

Needle Roller Bearings



Needle Roller Bearings Contents

Needle roller bearings	E- 2
Needle roller and cage assemblies	E- 12
Drawn cup needle roller bearings	E- 26
Machined-ring needle roller bearings	E- 34
Thrust cylindrical roller bearings	E- 56
Thrust needle roller bearings	E- 62
Cam follower stud type track rollers	E- 66
Roller follower yoke type track rollers	E- 84

2.2 Needle roller bearing with cage

These needle roller bearings include needle rollers and cages that guide and hold the needle rollers. The structure is lightweight and compact because no inner ring or outer ring is used and the shaft and the housing are used as raceway surfaces.

Table 4 shows recommended fits for this bearing type, and Table 5 shows the diameter dimensional tolerance and classification of needle rollers. See section 2.1 for the accuracy and surface hardness necessary for shafts and housings serving as the raceway surfaces for these bearings.

The needle roller diameter variation included in a single assembly is within $2\ \mu\text{m}$, and the standard classification shown in Table 5 will be supplied if there is no particular designation. When two or more of the same bearings are to be used in tandem arrangement, it is necessary to use bearings having rollers of the same classification promote equal load sharing.

For caged needle roller bearings that are used for the connecting rod of small/medium reciprocating engines, see the special catalog "Needle Roller Bearings (CAT. No. 2300/E)."

Table 4 Fits recommended for needle roller bearings with cage

Shaft diameter mm	Recommended fits					
	Internal clearance less than normal		Normal clearance		Internal clearance greater than normal	
	Shaft	Housing	Shaft	Housing	Shaft	Housing
Up to 80	j5	G6	h5	G6	g6	G6
80 to 140	h5	G6	g5	G6	f6	G6
140 or more	h5	G6	f5	H6	f6	G6

Table 5 Diameter dimensional tolerance and classification of needle rollers

Label color	Tolerance range (μm)	Classification
Red	0 to -2	Standard
Navy	-1 to -3	
Blue	-2 to -4	
Black	-3 to -5	
White	-4 to -6	
Gray	-5 to -7	Sub standard
Green	-6 to -8	
Brown	-7 to -9	
Yellow	-8 to -10	

When a caged needle roller bearing is used as a single body to be directly guided in the axial direction by a shaft shoulder (see Fig. 2), any part coming into contact with the cage side surface must be sufficiently finished without burrs. For high speed or heavy load operation, the contact surface is hardened and finished by grinding.

When a cage is to be guided in the axial direction with a snap ring (see Fig. 2), a thrust ring is used between the cage and the snap ring so that the snap ring lugs do not come in contact with the cage directly.

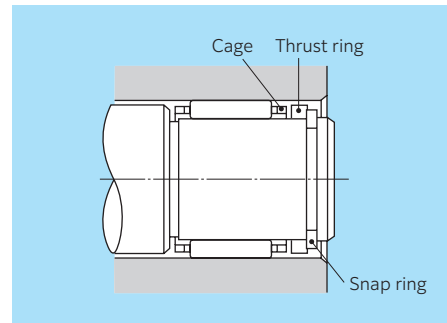

Fig. 2 Fixing using thrust ring

2.3 Drawn cup needle roller bearings

The outer ring of drawn cup needle roller bearings is formed by precision drawing from a thin steel plate, and is designed to have an appropriate accuracy for its intended function when press-fit into a rigid housing.

Therefore, it is meaningless to measure the dimensional accuracy of the bearing itself before press fitting. After pressing into a ring gage (with wall thickness of 20 mm or more) having appropriate dimensions, the bearing accuracy is evaluated by measuring the roller inscribed circle diameter (F_w) with a plug gage or a tapered gage.

Recommended fits for drawn cup needle roller bearings are shown in Table 6, and recommended shaft and housing accuracy is shown in Table 7. Table 8.1 and Table 8.2 show the dimensional tolerances of the ring gage bore diameter dimension and the roller inscribed circle diameter (F_w) with respect to the standard metric series HK and BK types and the heavy load series HMK type.

Table 6 Drawn cup needle roller bearing housing and shaft fits

Bearing type	Housing		Shaft	
	Iron-based	Light alloy	No inner ring	With an inner ring
HK, BK	N6 (N7)	R6 (R7)	h5 (h6)	k5 (j6)
HMK	J6 (J7)	M6 (M7)		

Table 7 Recommended shaft and housing accuracy

Characteristics	Shaft	Housing
Dimensional accuracy	IT6 (IT5)	IT7 (IT6)
Roundness (Max.)	IT3	IT4
Cylindricity (Max.)	IT3	IT3
Abutment squareness (Max.)	IT3	IT3
Fitting surface roughness Ra	0.8	1.6

Note: Accuracy in () applies to bearings of accuracy Class 5 and higher.

When a plug gage is used for the measurement of the roller inscribed circle diameter (F_w), the dimension of the go side is the lower limit of the dimensional tolerance of the roller inscribed circle diameter, and the dimension of the no-go side is the value obtained by adding $2\ \mu\text{m}$ to the upper limit of the dimensional tolerance of the roller inscribed circle diameter.

Since the outer ring is formed by a thin steel plate, the safety factor (S_0) when the bearing is used must be $S_0 \geq 3$ for standard specifications, and $S_0 \geq 2$ must be maintained for the carburized/quenched specification (HK-F type drawn cup needle roller bearings¹⁾).

1) HK-F type drawn cup needle roller bearings
For details, see the special catalog "HK-F Type Drawn Cup Needle Roller Bearings (CAT. No. 3029/JE)." (Suffix code F is added to the bearing number.)

Table 8.1 Accuracy of drawn cup needle roller bearings (1)

Dimensional tolerance of roller inscribed circle diameter (HK and BK types) Unit: mm

Nominal roller inscribed circle diameter F_w	Nominal outer ring outside diameter D	Ring gauge bore diameter	Dimensional tolerance of roller inscribed circle diameter	
			Upper limit	Lower limit
3	6.5	6.484	3.016	3.006
4	8	7.984	4.022	4.010
5	9	8.984	5.022	5.010
6	10	9.984	6.022	6.010
7	11	10.980	7.028	7.013
8	12	11.980	8.028	8.013
9	13	12.980	9.028	9.013
10	14	13.980	10.028	10.013
12	16	15.980	12.034	12.016
12	18	17.980	12.034	12.016
13	19	18.976	13.034	13.016
14	20	19.976	14.034	14.016
15	21	20.976	15.034	15.016
16	22	21.976	16.034	16.016
17	23	22.976	17.034	17.016
18	24	23.976	18.034	18.016
20	26	25.976	20.041	20.020
22	28	27.976	22.041	22.020
25	32	31.972	25.041	25.020
28	35	34.972	28.041	28.020
30	37	36.972	30.041	30.020
35	42	41.972	35.050	35.025
40	47	46.972	40.050	40.025
45	52	51.967	45.050	45.025
50	58	57.967	50.050	50.025

When a drawn cup needle roller bearing is to be inserted into a housing, **the marked side of the bearing must be press-fit into the appropriate position with the use of a jig.** (There is no designation for the installation direction of pre-bent specification products¹⁾.)

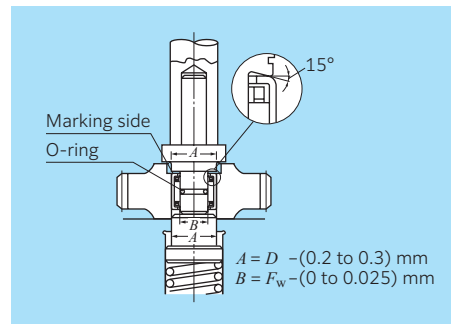

Fig. 3

Table 8.2 Accuracy of drawn cup needle roller bearings (2)

Dimensional tolerance of roller inscribed circle diameter (HMK type) Unit: mm

Nominal roller inscribed circle diameter F_w	Nominal outer ring outside diameter D	Ring gauge bore diameter	Dimensional tolerance of roller inscribed circle diameter	
			Upper limit	Lower limit
8	15	14.995	8.028	8.013
9	16	15.995	9.028	9.013
10	17	16.995	10.028	10.013
12	19	18.995	12.034	12.016
14	22	21.995	14.034	14.016
15	22	21.995	15.034	15.016
16	24	23.995	16.034	16.016
17	24	23.995	17.034	17.016
18	25	24.995	18.034	18.016
19	27	26.995	19.041	19.020
20	27	26.995	20.041	20.020
21	29	28.995	21.041	21.020
22	29	28.995	22.041	22.020
24	31	30.994	24.041	24.020
25	33	32.994	25.041	25.020
26	34	33.994	26.041	26.020
28	37	36.994	28.041	28.020
29	38	37.994	29.041	29.020
30	40	39.994	30.041	30.020
32	42	41.994	32.050	32.025
35	45	44.994	35.050	35.025
37	47	46.994	37.050	37.025
38	48	47.994	38.050	38.025
40	50	49.994	40.050	40.025
45	55	54.994	45.050	45.025
50	62	61.994	50.050	50.025

The bearings must not be directly struck by a hammer when being installed. Use an installation jig like that shown in **Fig. 3**, having a mandrel equipped with an O-ring for ease of installation, should be used to ensure the bearing will not fall off or become damaged during installation.

When inserting an inner ring or a shaft into a drawn cup needle roller bearing installed in a housing, insert it straightly by aligning the central axis of the inner ring or the shaft with the central axis of the housing.

Since a drawn cup needle roller bearing is positioned by means of the housing, it is unnecessary to provide a snap ring or a shoulder. However, when a drawn cup needle roller bearing is to be press-fitted into a housing having a shoulder, it is necessary to pay attention to prevent the bearing side surface from contacting the shoulder, thereby causing deformation of the bearing.

1) Pre-bent specification

The outer ring rib is hardened on both sides by heat treating the outer ring after inserting the cage and rollers and bending the edge of the ring. Thus, bearings can be press-fitted from any direction compared with conventional products, which required applying a jig on the outer ring marking side. (Suffix code M is added to the bearing number.)

2.4 Solid type needle roller bearings

These bearings have a non-separable construction held together by ribs or side plates on both sides of the outer ring, with needle rollers and cages contained within a solid (machined) outer ring. Since the outer ring is solid (machined), it has high rigidity and the bearing accuracy can be increased; therefore, the bearings are suitable for applications that require high speed, heavy load, and high rotational accuracy.

There are two types of solid type needle roller bearings: one having an inner ring and one having no inner ring. Bearings without an inner ring use the shaft directly as a raceway surface, and the required dimensional tolerance of the shaft diameter (raceway diameter) is as shown in **Table 9** based on required operating clearance (see **Table 1** required accuracy of other parameters). The corresponding dimensional tolerance of the housing bore is set to K7, which is widely used in general. Please consult **NTN Engineering** when setting the dimensional tolerance of the housing bore to other classes.

Table 9 Dimensional tolerance for shaft (raceway diameter)

Roller inscribed circle diameter F_w mm	Shaft tolerance class			
	Internal clearance less than normal	Normal clearance	Internal clearance greater than normal	
Over	Incl.			
80	160	k5	h5	f6
160	180	k5	g5	f6
180	200	j5	g5	e6
200	250	j5	f6	e6
250	315	h5	f6	e6
315	400	g5	f6	d6

Table 10.1 and Table 10.2 show values of the radial internal clearance of bearings with an inner ring. Table 10.1 shows the clearance of interchangeable bearings, and the clearance values are satisfied even if the inner rings and outer rings are intermixed. Table 10.2 shows the clearance of non-interchangeable bearings, and the clearance range is tightly controlled. Therefore, the inner rings and outer rings cannot be intermixed. The clearance codes are C2, normal, C3, and C4 from smallest to largest, and suffix code NA is added for the non-interchangeable clearance.

When there is an oil hole on the raceway surface, bearings should be installed such that the oil hole position is located in the non-loaded region. A bearing with an inner ring must be used within the allowable movement amount (s) (a state in which the rollers are within the range of the inner ring effective contact length). The allowable movement amount (s) is illustrated in Fig. 4, values are listed in the bearing dimension tables.

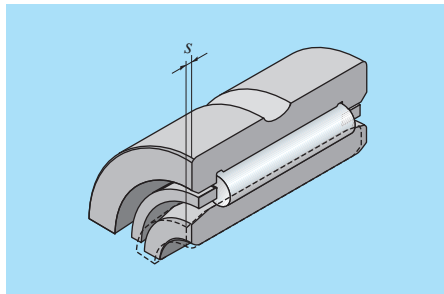

Fig. 4 Allowable movement amount (s)

Table 10.1 Radial internal clearance of solid type needle roller bearings (1) interchangeable bearings Unit: μm

Nominal bearing bore diameter d mm	Over	Incl.	C2		Normal ¹⁾		C3		C4	
			Min.	Max.	Min.	Max.	Min.	Max.	Min.	Max.
—	10		0	30	10	40	25	55	35	65
10	18		0	30	10	40	25	55	35	65
18	24		0	30	10	40	25	55	35	65
24	30		0	30	10	45	30	65	40	70
30	40		0	35	15	50	35	70	45	80
40	50		5	40	20	55	40	75	55	90
50	65		5	45	20	65	45	90	65	105
65	80		5	55	25	75	55	105	75	125
80	100		10	60	30	80	65	115	90	140
100	120		10	65	35	90	80	135	105	160
120	140		10	75	40	105	90	155	115	180
140	160		15	80	50	115	100	165	130	195
160	180		20	85	60	125	110	175	150	215
180	200		25	95	65	135	125	195	165	235
200	225		30	105	75	150	140	215	180	255
225	250		40	115	90	165	155	230	205	280
250	280		45	125	100	180	175	255	230	310
280	315		50	135	110	195	195	280	255	340
315	355		55	145	125	215	215	305	280	370
355	400		65	160	140	235	245	340	320	415
400	450		70	190	155	275	270	390	355	465

1) No clearance code is given to this type of bearings.

Table 10.2 Radial internal clearance of solid type needle roller bearings (2) non-interchangeable bearings Unit: μm

Nominal bearing bore diameter d mm	Over	Incl.	C2NA		Normal ¹⁾		C3NA		C4NA	
			Min.	Max.	Min.	Max.	Min.	Max.	Min.	Max.
—	10		10	20	20	30	35	45	45	55
10	18		10	20	20	30	35	45	45	55
18	24		10	20	20	30	35	45	45	55
24	30		10	25	25	35	40	50	50	60
30	40		12	25	25	40	45	55	55	70
40	50		15	30	30	45	50	65	65	80
50	65		15	35	35	50	55	75	75	90
65	80		20	40	40	60	70	90	90	110
80	100		25	45	45	70	80	105	105	125
100	120		25	50	50	80	95	120	120	145
120	140		30	60	60	90	105	135	135	160
140	160		35	65	65	100	115	150	150	180
160	180		35	75	75	110	125	165	165	200
180	200		40	80	80	120	140	180	180	220
200	225		45	90	90	135	155	200	200	240
225	250		50	100	100	150	170	215	215	265
250	280		55	110	110	165	185	240	240	295
280	315		60	120	120	180	205	265	265	325
315	355		65	135	135	200	225	295	295	360
355	400		75	150	150	225	255	330	330	405
400	450		85	170	170	255	285	370	370	455

1) Only code "NA" is given to this type of bearings. Example: NA4920NA

2.5 Thrust roller bearing

Thrust roller bearings are bearings having a disc-shaped raceway combined with a cage-and-roller assembly having needle rollers or cylindrical rollers radially embedded, and are suitable for axial loads applied in a single direction.

Further, a shaft or housing can be directly used as a raceway surface without using a separate raceway ring. Thereby, size in the axial direction can be minimized, and lightweight and compact designs can be obtained. Table 11 shows fits recommended for thrust roller bearings. See Table 1 for the required accuracy of the raceway surface.

Table 11 Fits recommended for thrust roller bearings

Bearing parts		Type and class	
		Shaft diameter	Housing bore
AXK type, K811 type	Bore diameter guide	h8 ¹⁾	—
	Outside diameter guide	—	H9 ¹⁾
WS type raceway (inner ring)		h6	—
GS type raceway (outer ring)		—	H7
Steel raceway AS type	Shaft fixing	h10	Clearance with housing
	Housing fixing	Clearance with shaft	H11

1) The guide surface is finished by grinding.

2.6 Cam follower/roller follower

A cam follower is a track roller having a stud in place of an inner ring, and the outer ring rolls on a track. It is a bearing used as an eccentric roller, a guide roller, etc., and it can have a cylindrical shape or a spherical shape for the outer ring outside diameter. Cam follower bearings are offered in both cage type and full complement designs.

When attaching a cam follower do not strike the rib part with a hammer because sharp impact may cause cracks and rotational failure (see Fig. 5). In addition, the oil supply hole position on the stud raceway surface of the cam follower is indicated by the NTN mark on the stud rib surface. Install it by rotating the nut while the fixing the stud so that the mark (oil hole) is positioned in the non-loaded region (see Fig. 6). The thread part may break if too much tightening torque is applied.

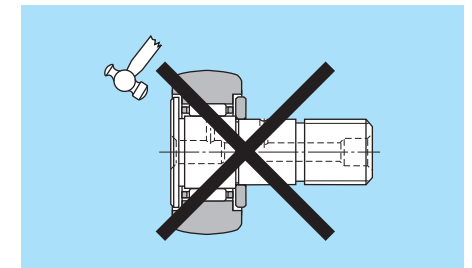

Fig. 5

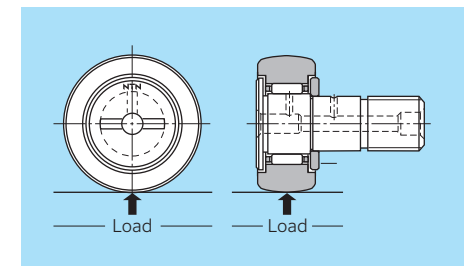

Fig. 6

A roller follower is a bearing in which the outer ring rolls on a track. As with the cam follower, there is a cylindrical shape or a spherical shape for the outer ring outside diameter, and are offered in both cage type and full complement designs. Common uses include use as an eccentric roller, guide roller, rocker arm roller, cam roller, pressure roller, etc.

A roller follower must be installed so that the oil hole is positioned in the non-loaded region because installing the oil hole position of the inner ring in the loaded region may shorten the bearing life.

Table 12 shows the radial internal clearance of cam followers and roller followers, Table 13 and Table 14 show the dimensional accuracy and recommended fits of cam followers, and Table 15 shows the recommended fits of roller followers.

Table 12 Radial internal clearance of cam followers and roller followers Unit: μm

Nominal roller inscribed circle diameter F_w mm	Over	Incl.	C2		CN (normal)		C3		C4	
			Min.	Max.	Min.	Max.	Min.	Max.	Min.	Max.
3	6	0	10	3	17	15	30	20	40	
6	10	0	12	5	20	15	30	25	45	
10	18	0	15	5	25	15	35	30	55	
18	30	0	20	10	30	20	40	40	65	
30	50	0	25	10	40	25	55	50	80	
50	80	0	30	15	50	30	65	60	100	
80	100	0	35	20	55	35	75	70	115	

Table 13 Dimensional accuracy of cam followers Unit: μm

Bearing	Outer ring shape	Stud diameter	Outer ring outside diameter	Outer ring width
Metric series	Spherical surface	h7	0 -50	JIS Class 0
	Cylindrical surface		JIS Class 0	
Inch series	Spherical surface	+25	0 -50	0 -130
	Cylindrical surface	0	0 -25	

Table 14 Fits recommended for cam followers

Bearing	Type and class of mounting hole
Metric series	H7
Inch series	F7

Note: Assembly must be done without backlash for impact loads.

Table 15 Fits recommended for roller followers

Type and class of shaft	
Without an inner ring	With an inner ring
k5 or k6	g6 or h6

The maximum radial load that can be statically permitted on the contact surface between the track and the track roller is referred to as the track load capacity, and the value differs depending on the hardness of the track. The track load capacity specified in the dimension table is a value considering a track hardness of HRC 40, and the load capacity of tracks having different hardness may be obtained by multiplying the track load capacity in the dimension table by the correction coefficient G in Table 16. However, when the calculated track load capacity exceeds the basic static rating load C_{0r} of the bearing, the track load capacity is equal to the basic static rating load C_{0r} of the bearing.

Table 16 Correction coefficient G

Hardness (HRC)	Correction coefficient G	
	Cylindrical shape	Spherical shape
20	0.368	0.223
25	0.459	0.311
30	0.583	0.446
35	0.750	0.650
40	1.000	1.000
45	1.414	1.681
50	1.987	2.800
55	2.787	4.652

Since NTN cam followers and roller followers are generally installed with cantilever loading, a non-uniform load (one-sided load) may act on the bearing due to the influence of loosening of the fitting caused by continuous use. For stable operation of equipment, it is necessary to pay sufficient attention to the looseness of the fitting.

Further, lubrication is also necessary between the outer ring outside diameter surface and the track of the bearing. Even after lubrication, the bearing and the track may be damaged at an early stage when slippage occurs between the outer ring outside diameter surface and the track of the bearing due to rapid radial load fluctuation or rotational speed fluctuation during use.

For details, see the special catalog "Needle Roller Bearings (CAT. No. 2300/E)" or "Cam Followers & Roller Followers (CAT. No. 3604/ JE)."

Needle Roller Bearings

Needle roller and cage assemblies

- K type
- K·T2 type
- K·S type
- K·ZW type
- KMJ·S type
- KV·S type

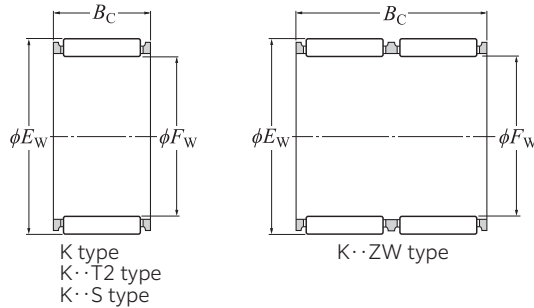

Needle Roller Bearings

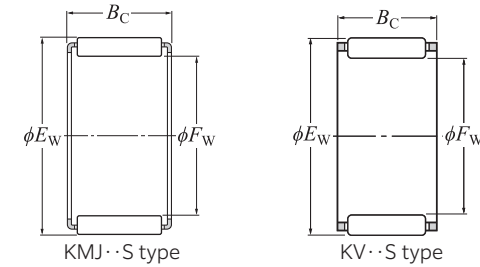

F_w 3-10 mm

Boundary dimensions	Basic load rating		Fatigue load limit	Allowable speed		Number	Mass
	dynamic	static		min ⁻¹			
mm	C_r	C_{0r}	min ⁻¹				
F_w E_w B_c	C_r	C_{0r}	Grease lubrication	Oil lubrication			kg (approx.)
3 6 7 ^{-0.2} / _{-0.55}	1 460	970	118	33 000 50 000	K3×6×7T2T	0.0004	
4 6 8 ^{-0.2} / _{-0.55}	1 560	1 330	162	30 000 45 000	K4×6×7.8XT2	0.0003	
	1 770	1 270	155	30 000 45 000	K4×7×7T2	0.0005	
5 8 8 ^{-0.2} / _{-0.55}	2 640	2 190	267	27 000 40 000	K5×8×8T2	0.0007	
	2 720	2 250	275	27 000 40 000	K5×8×10T2	0.0009	
6 9 8 ^{-0.2} / _{-0.55}	2 660	2 280	278	25 000 37 000	K6×9×8T2T	0.0009	
	3 400	3 150	380	25 000 37 000	K6×9×10T2T	0.0011	
	4 400	3 700	455	25 000 37 000	K6×10×13T2	0.0019	
7 10 8 ^{-0.2} / _{-0.55}	2 670	2 350	286	23 000 34 000	K7×10×8T2	0.0009	
	3 400	3 200	390	23 000 34 000	K7×10×10T2	0.0011	
	5 050	5 400	655	23 000 34 000	KV7×10×12.8X3S	0.0023	
8 11 8 ^{-0.2} / _{-0.55}	3 150	3 000	365	21 000 32 000	K8×11×8T2T	0.0011	
	3 150	3 000	365	21 000 32 000	8E-KV8×11×8.8X2S	0.0019	
	4 000	4 100	500	21 000 32 000	K8×11×10T2	0.0013	
	4 450	4 650	570	21 000 32 000	8E-KV8×11×11.8X2S	0.0025	
	4 850	5 200	635	21 000 32 000	K8×11×13	0.0026	
	4 650	4 150	510	21 000 32 000	K8×12×10T2	0.0020	
	5 600	5 300	650	21 000 32 000	8E-KV8×12×11.8X1S	0.0040	
5 050	4 650	565	21 000 32 000	K8×12×13	0.0036		
9 12 10 ^{-0.2} / _{-0.55}	4 550	5 000	615	20 000 30 000	K9×12×10T2	0.0015	
	5 500	6 400	780	20 000 30 000	K9×12×13T2	0.0021	
10 13 10 ^{-0.2} / _{-0.55}	4 550	5 100	620	19 000 28 000	K10×13×10T2T	0.0016	
	5 450	6 450	790	19 000 28 000	8E-KV10×13×12.8XS	0.0032	
	4 300	3 950	485	19 000 28 000	K10×14×8	0.0027	
	5 500	5 450	660	19 000 28 000	K10×14×10T	0.0034	
	5 500	5 450	660	19 000 28 000	8E-KV10×14×10.8XS	0.0039	
	6 800	7 200	875	19 000 28 000	KMJ10×14×11.3XS	0.0040	
	6 600	6 900	840	19 000 28 000	K10×14×13	0.0044	
7 150	7 650	930	19 000 28 000	8E-KV10×14×13.8X4S	0.0050		

Note: Bearings may be delivered with a different cage type even if they are ordered by the bearing numbers in the table.

F_w 10-15 mm

Boundary dimensions	Basic load rating		Fatigue load limit	Allowable speed		Number	Mass
	dynamic	static		min ⁻¹			
mm	C_r	C_{0r}	min ⁻¹				
F_w E_w B_c	C_r	C_{0r}	Grease lubrication	Oil lubrication			kg (approx.)
10 14 17 ^{-0.2} / _{-0.55}	8 050	8 850	1 080	19 000 28 000	8E-K10×14×16.8X1	0.0064	
	7 100	5 950	730	19 000 28 000	K10×16×12	0.0066	
11 14 10 ^{-0.2} / _{-0.55}	5 050	6 000	735	18 000 27 000	K11×14×10	0.0028	
12 15 9 ^{-0.2} / _{-0.55}	4 450	5 250	640	17 000 26 000	K12×15×9	0.0027	
	5 000	6 100	740	17 000 26 000	8Q-K12×15×10	0.0030	
	6 000	7 700	940	17 000 26 000	K12×15×13	0.0038	
	8 550	12 200	1 480	17 000 26 000	K12×15×20ZW	0.0059	
	4 850	4 900	600	17 000 26 000	K12×16×8	0.0034	
	6 750	7 400	900	17 000 26 000	KMJ12×16×11.3XS	0.0047	
	7 500	8 500	1 040	17 000 26 000	8Q-K12×16×13	0.0060	
	9 800	11 900	1 460	17 000 26 000	8E-K12×16×17.8X1	0.0070	
	10 300	12 800	1 560	17 000 26 000	K12×16×19.8X4	0.010	
	7 350	7 200	880	17 000 26 000	KMJ12×17×9.8XS	0.0050	
14 17 10 ^{-0.2} / _{-0.55}	9 000	9 400	1 150	17 000 26 000	K12×17×13	0.0075	
	12 600	14 400	1 760	17 000 26 000	KV12×17×17.8XS	0.0080	
	8 650	8 000	975	17 000 26 000	8Q-K12×18×12	0.0089	
	5 400	7 050	860	16 000 24 000	KV14×17×10ST	0.0040	
	6 900	8 000	975	16 000 24 000	K14×18×10	0.0046	
	7 600	9 050	1 100	16 000 24 000	K14×18×11	0.0053	
	8 300	10 100	1 240	16 000 24 000	K14×18×13	0.0063	
	9 650	12 300	1 500	16 000 24 000	K14×18×15S	0.0076	
15 18 14 ^{-0.2} / _{-0.55}	10 900	14 400	1 760	16 000 24 000	K14×18×17V5	0.0079	
	18 800	28 900	3 500	16 000 24 000	K14×18×39ZW	0.018	
	8 950	9 650	1 180	16 000 24 000	K14×19×13	0.0080	
	9 350	9 150	1 110	16 000 24 000	K14×20×12	0.0095	
	13 500	14 600	1 780	16 000 24 000	K14×20×17	0.014	
	7 850	11 600	1 420	15 000 23 000	K15×18×14	0.0060	
	5 350	5 850	715	15 000 23 000	KV15×19×7.8XS	0.0033	
15 19 10 ^{-0.2} / _{-0.55}	6 850	8 050	980	15 000 23 000	K15×19×10T	0.0055	
	8 250	10 200	1 250	15 000 23 000	K15×19×13	0.0067	

Note: Bearings may be delivered with a different cage type even if they are ordered by the bearing numbers in the table.

Needle Roller Bearings

Needle roller and cage assemblies

- K type
- K·T2 type
- K·S type
- K·ZW type
- KMJ·S type

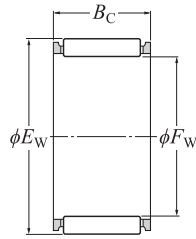

K type
K·T2 type
K·S type

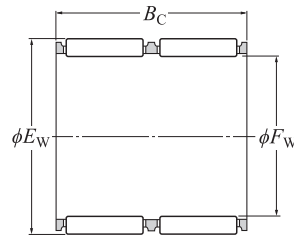

K·ZW type

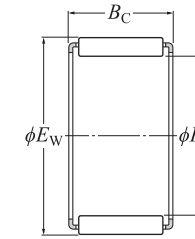

KMJ·S type

F_w 15-18 mm

Boundary dimensions			Basic load rating		Fatigue load limit N C_u	Allowable speed		Number	Mass kg (approx.)	
F_w	E_w	B_c	dynamic C_r	static C_{0r}		min ⁻¹ Grease lubrication	Oil lubrication			
15	19	17	10 900	14 600	1 780	15 000	23 000	K15×19×17	0.0090	
	19	24	14 100	20 400	2 490	15 000	23 000	K15×19×24ZW	0.013	
	20	13	10 100	11 500	1 410	15 000	23 000	K15×20×13	0.0088	
	20	16	-0.2 -0.55	12 600	15 200	1 850	15 000	23 000	KMJ15×20×15.8XS	0.0090
	21	15	11 900	12 500	1 530	15 000	23 000	K15×21×15	0.013	
	21	17	14 900	16 800	2 050	15 000	23 000	KMJ15×21×16.8X1SK	0.012	
	21	21	16 500	19 100	2 330	15 000	23 000	K15×21×21	0.017	
16	20	10	7 500	9 250	1 130	15 000	23 000	K16×20×10T	0.0057	
	20	11	8 300	10 500	1 280	15 000	23 000	K16×20×11T	0.0061	
	20	13	9 050	11 800	1 430	15 000	23 000	K16×20×13	0.0071	
	20	17	11 900	16 800	2 050	15 000	23 000	K16×20×17ST	0.0092	
	22	12	-0.2 -0.55	11 700	12 500	1 530	15 000	23 000	K16×22×12	0.010
	22	13	12 600	13 900	1 690	15 000	23 000	KMJ16×22×13S	0.011	
	22	16	13 600	15 200	1 850	15 000	23 000	K16×22×15.8X	0.014	
	22	17	14 400	16 400	2 000	15 000	23 000	K16×22×17	0.015	
	22	20	16 000	18 800	2 300	15 000	23 000	K16×22×20	0.017	
17	21	10	7 450	9 300	1 140	15 000	22 000	K17×21×10S	0.0056	
	21	13	9 400	12 600	1 530	15 000	22 000	K17×21×13S	0.0075	
	21	15	10 400	14 400	1 750	15 000	22 000	K17×21×15	0.0089	
	21	17	-0.2 -0.55	11 800	16 900	2 060	15 000	22 000	K17×21×17	0.0095
	22	20	14 700	19 200	2 340	15 000	22 000	K17×22×20	0.015	
	23	17	14 400	16 500	2 020	15 000	22 000	K17×23×17	0.016	
18	23	23	16 800	20 200	2 470	15 000	22 000	K17×23×22.8X1T2	0.013	
	22	10	7 400	9 400	1 140	14 000	21 000	K18×22×10	0.0061	
	22	13	8 900	11 900	1 450	14 000	21 000	K18×22×13	0.0077	
	22	17	-0.2 -0.55	11 700	17 000	2 070	14 000	21 000	K18×22×17	0.011
	23	20	14 600	19 300	2 360	14 000	21 000	K18×23×20S	0.015	
	24	12	12 300	13 800	1 690	14 000	21 000	K18×24×12	0.012	
24	13	11 600	12 800	1 560	14 000	21 000	K18×24×13	0.013		

Note: Bearings may be delivered with a different cage type even if they are ordered by the bearing numbers in the table.

Needle Roller Bearings

F_w 18-22 mm

Boundary dimensions			Basic load rating		Fatigue load limit N C_u	Allowable speed		Number	Mass kg (approx.)	
F_w	E_w	B_c	dynamic C_r	static C_{0r}		min ⁻¹ Grease lubrication	Oil lubrication			
18	24	17	16 000	19 300	2 350	14 000	21 000	KMJ18×24×17SV1	0.014	
	24	20	-0.2 -0.55	17 000	20 900	2 550	14 000	21 000	K18×24×20	0.019
	25	17	18 000	20 400	2 490	14 000	21 000	K18×25×17	0.019	
	25	22	22 100	26 600	3 250	14 000	21 000	K18×25×22	0.024	
	19	23	13	-0.2 -0.55	9 650	13 500	1 640	14 000	21 000	K19×23×13
23		17	12 700	19 200	2 340	14 000	21 000	K19×23×17	0.011	
20	24	10	8 300	11 200	1 370	13 000	20 000	K20×24×10S	0.0065	
	24	11	9 500	13 400	1 640	13 000	20 000	K20×24×11	0.0072	
	24	13	10 000	14 300	1 740	13 000	20 000	K20×24×13SV4	0.0086	
	24	17	13 200	20 400	2 480	13 000	20 000	K20×24×17S	0.011	
	24	45	16 400	27 100	3 300	13 000	20 000	K20×24×45ZW	0.028	
	25	40	29 000	48 000	5 880	13 000	20 000	K20×25×40ZW	0.033	
	26	12	-0.2 -0.55	12 900	15 100	1 840	13 000	20 000	K20×26×12	0.013
	26	13	14 000	16 700	2 040	13 000	20 000	KMJ20×26×13ST	0.012	
	26	14	15 800	19 600	2 390	13 000	13 000	KMJ20×26×13.8X1S	0.013	
	26	17	17 800	22 800	2 780	13 000	20 000	KMJ20×26×17S	0.016	
	26	20	20 600	27 600	3 350	13 000	20 000	KMJ20×26×20S	0.019	
	28	17	21 700	24 600	3 000	13 000	20 000	KMJ20×28×16.8XS	0.022	
	28	20	24 600	28 900	3 500	13 000	20 000	KMJ20×28×19.8X4S	0.026	
28	25	27 100	32 500	3 950	13 000	20 000	8Q-K20×28×25	0.039		
21	25	13	-0.2 -0.55	10 700	15 900	1 940	13 000	19 000	KMJ21×25×12.8X1S	0.0081
	25	17	13 600	21 500	2 630	13 000	19 000	K21×25×17	0.012	
22	26	10	8 500	11 900	1 450	12 000	18 000	K22×26×10S	0.0071	
	26	11	10 100	14 900	1 820	12 000	18 000	8Q-K22×26×11	0.0090	
	26	13	10 200	15 200	1 850	12 000	18 000	K22×26×13	0.0094	
	26	17	-0.2 -0.55	13 500	21 600	2 640	12 000	18 000	K22×26×17S	0.012
	27	20	17 500	25 900	3 150	12 000	18 000	K22×27×20	0.020	
	27	28.5	24 200	39 500	4 800	12 000	18 000	K22×27×28.3X	0.028	
	27	40	29 900	51 500	6 300	12 000	18 000	K22×27×40ZW	0.039	
	28	17	17 700	23 300	2 850	12 000	18 000	K22×28×17V1	0.020	

Note: Bearings may be delivered with a different cage type even if they are ordered by the bearing numbers in the table.

Needle Roller Bearings



Needle roller and cage assemblies

- K type
- K·T2 type
- K·S type
- K·ZW type
- KMJ·S type
- KV·S type

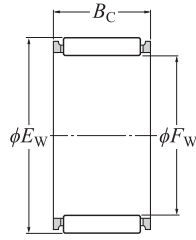

K type
K·T2 type
K·S type

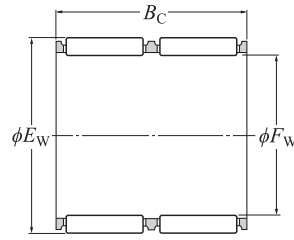

K·ZW type

F_w 22–25 mm

Boundary dimensions	Basic load rating		Fatigue load limit	Allowable speed		Number	Mass	
	dynamic	static		min ⁻¹				
mm	C_r	C_{0r}	C_u	Grease lubrication	Oil lubrication		kg	
F_w E_w B_c	N	N	N				(approx.)	
22	29 16	18 700	22 700	2 770	12 000	18 000	K22×29×16	0.023
	30 15	19 300	21 700	2 640	12 000	18 000	K22×30×15T	0.022
	30 17.5	23 200	27 500	3 350	12 000	18 000	KMJ22×30×17.3X2S	0.024
	30 24	31 000	40 000	4 900	12 000	18 000	KMJ22×30×23.8X3S	0.035
23	27 13	11 400	17 700	2 160	11 000	17 000	KMJ23×27×12.8X1S	0.0086
	28 24	19 800	31 000	3 750	11 000	17 000	K23×28×24	0.023
	29 18	20 600	28 800	3 500	11 000	17 000	KMJ23×29×17.8X2S	0.019
24	28 10	9 000	13 200	1 610	11 000	17 000	K24×28×10T	0.0080
	28 13	10 800	16 800	2 050	11 000	17 000	K24×28×13	0.010
	28 17	14 300	23 900	2 920	11 000	17 000	K24×28×17	0.013
	29 13	12 300	16 900	2 060	11 000	17 000	K24×29×13	0.012
	30 17	18 400	25 200	3 050	11 000	17 000	K24×30×17	0.022
	30 31	27 900	43 000	5 200	11 000	17 000	K24×30×31ZW	0.039
25	29 10	8 950	13 300	1 620	11 000	16 000	K25×29×10	0.0083
	29 13	10 800	16 900	2 050	11 000	16 000	K25×29×13	0.010
	29 17	14 200	24 000	2 930	11 000	16 000	K25×29×17S	0.014
	30 13	13 200	18 800	2 290	11 000	16 000	K25×30×13	0.013
	30 17	17 400	26 800	3 250	11 000	16 000	K25×30×17S	0.017
	30 20	19 400	31 000	3 750	11 000	16 000	K25×30×20SV3	0.021
	30 22	22 300	37 000	4 500	11 000	16 000	KMJ25×30×21.8XS	0.020
	30 26	21 800	35 500	4 350	11 000	16 000	K25×30×26ZW	0.027
	30 39	29 800	53 500	6 550	11 000	16 000	K25×30×39ZW	0.040
	31 13	15 200	19 900	2 430	11 000	16 000	K25×31×13V3	0.018
	31 14	16 500	22 100	2 700	11 000	16 000	K25×31×14	0.018
	31 17	18 300	25 300	3 100	11 000	16 000	K25×31×17	0.022
	31 18.5	21 000	30 000	3 650	11 000	16 000	KMJ25×31×18.3X1SK	0.021
	31 21	22 500	33 000	4 000	11 000	16 000	K25×31×21V3	0.028
	32 16	19 500	24 700	3 000	11 000	16 000	K25×32×16	0.027
33 24	34 500	47 000	5 750	11 000	16 000	KMJ25×33×24S	0.040	

Note: Bearings may be delivered with a different cage type even if they are ordered by the bearing numbers in the table.

Needle Roller Bearings

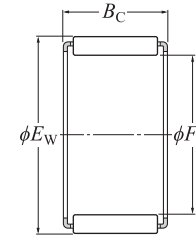

KMJ·S type

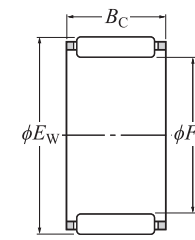

KV·S type

F_w 26–30 mm

Boundary dimensions	Basic load rating		Fatigue load limit	Allowable speed		Number	Mass	
	dynamic	static		min ⁻¹				
mm	C_r	C_{0r}	C_u	Grease lubrication	Oil lubrication		kg	
F_w E_w B_c	N	N	N				(approx.)	
26	30 13	11 800	19 200	2 340	10 000	15 000	K26×30×13	0.011
	30 17	15 500	27 400	3 350	10 000	15 000	K26×30×17	0.015
	31 24	21 400	35 500	4 300	10 000	15 000	8E-K26×31×23.8X1ZW	0.029
	34 22	24 200	30 000	3 700	10 000	15 000	K26×34×22	0.041
28	32 17	15 300	27 500	3 350	9 500	14 000	K28×32×17	0.017
	32 21	18 700	35 500	4 350	9 500	14 000	K28×32×21T	0.020
	33 13	13 900	20 900	2 550	9 500	14 000	K28×33×13	0.015
	33 17	18 300	29 800	3 650	9 500	14 000	K28×33×17S	0.020
	33 26	23 900	42 000	5 100	9 500	14 000	K28×33×26ZW	0.033
	33 27	28 300	52 000	6 350	9 500	14 000	K28×33×27	0.032
	34 14	17 500	24 800	3 000	9 500	14 000	K28×34×14	0.020
	34 17	18 100	25 800	3 150	9 500	14 000	K28×34×17V1	0.025
	35 16	21 200	28 400	3 450	9 500	14 000	K28×35×16	0.029
	35 18	21 500	28 900	3 550	9 500	14 000	K28×35×18	0.031
29	34 17	18 900	31 000	3 800	9 500	14 000	K29×34×17S	0.022
	34 27	28 100	52 000	6 350	9 500	14 000	K29×34×27	0.033
30	34 14	12 400	21 500	2 600	8 500	13 000	KV30×34×13.8XS	0.014
	34 23	18 000	34 500	4 200	8 500	13 000	K30×34×22.8X1T2	0.013
	35 11	12 200	18 000	2 200	8 500	13 000	K30×35×11S	0.014
	35 13	14 700	22 900	2 800	8 500	13 000	KV30×35×13S	0.017
	35 20	21 600	37 500	4 600	8 500	13 000	K30×35×20S	0.025
	35 26	25 200	46 000	5 600	8 500	13 000	K30×35×26ZWV1	0.036
	35 27	29 900	57 000	6 950	8 500	13 000	K30×35×27S	0.033
	37 16	21 900	30 500	3 700	8 500	13 000	K30×37×16	0.029
	37 18	23 300	33 000	4 000	8 500	13 000	K30×37×18	0.034
	37 20	26 200	38 000	4 650	8 500	13 000	KMJ30×37×20S	0.032
	37 48	40 000	65 500	8 000	8 500	13 000	K30×37×48ZW	0.075
	38 18	25 000	33 000	4 000	8 500	13 000	K30×38×18	0.036

Note: Bearings may be delivered with a different cage type even if they are ordered by the bearing numbers in the table.

Needle Roller Bearings

Needle roller and cage assemblies

- K type
- K·T2 type
- K·S type
- K·ZW type
- KMJ·S type
- KV·S type

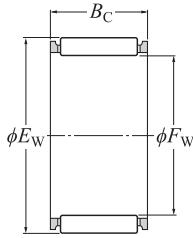

K type
K·T2 type
K·S type

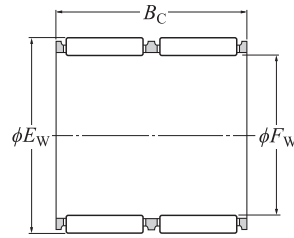

K·ZW type

F_w 31–35 mm

Boundary dimensions	Basic load rating		Fatigue load limit N C_u	Allowable speed		Number	Mass kg (approx.)	
	dynamic C_r	static C_{0r}		min ⁻¹ Grease lubrication	Oil lubrication			
mm F_w E_w B_c								
31	35 24	21 200	43 500	5 300	8 500	13 000	KV31×35×23.8XS	0.022
	36 14	15 800	25 400	3 100	8 500	13 000	KV31×36×13.8XS	0.017
32	36 15	14 300	26 400	3 200	8 500	13 000	K32×36×15ST	0.017
	37 13	14 500	23 000	2 810	8 500	13 000	K32×37×13	0.018
	37 17	19 200	33 000	4 000	8 500	13 000	K32×37×17S	0.022
	37 26	24 900	46 000	5 600	8 500	13 000	K32×37×26ZWV3	0.032
	37 27	29 600	57 500	7 000	8 500	13 000	K32×37×27	0.037
	38 14	19 800	30 500	3 700	8 500	13 000	KMJ32×38×14S	0.022
	38 26	31 500	54 000	6 600	8 500	13 000	K32×38×26	0.041
	39 16	22 600	32 000	3 900	8 500	13 000	K32×39×16V1	0.033
39 18	24 000	35 000	4 250	8 500	13 000	K32×39×18	0.037	
33	38 30.5	28 400	55 000	6 700	8 000	12 000	K33×38×30.3X1T2	0.026
34	40 39.5	39 000	73 500	8 950	8 000	12 000	KV34×40×39.3X1ZWS	0.066
35	39 22.5	21 500	46 000	5 600	7 500	11 000	KV35×39×22.3XS	0.024
	39 24	21 300	45 000	5 500	7 500	11 000	K35×39×23.8X1T2	0.015
	40 13	15 200	25 100	3 050	7 500	11 000	K35×40×13	0.019
	40 17	20 000	36 000	4 350	7 500	11 000	K35×40×17	0.025
	40 19	22 300	41 000	5 000	7 500	11 000	K35×40×19	0.029
	40 26	26 100	50 000	6 100	7 500	11 000	K35×40×26ZW	0.037
	40 30	26 100	50 000	6 100	7 500	11 000	K35×40×30ZW	0.043
	41 14	19 400	30 500	3 700	7 500	11 000	K35×41×14	0.026
	41 15	20 900	33 500	4 050	7 500	11 000	K35×41×15	0.027
	41 24	31 000	55 500	6 800	7 500	11 000	K35×41×23.8X1	0.042
	41 40	43 000	84 000	10 200	7 500	11 000	K35×41×40ZW	0.055
	42 16	24 100	36 000	4 350	7 500	11 000	K35×42×16	0.035
	42 18	24 700	37 000	4 500	7 500	11 000	K35×42×18	0.039

Note: Bearings may be delivered with a different cage type even if they are ordered by the bearing numbers in the table.

Needle Roller Bearings

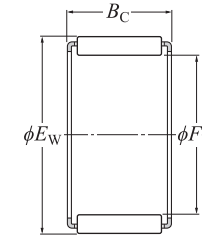

KMJ·S type

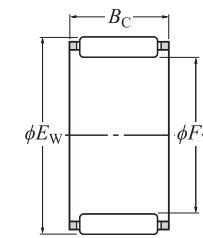

KV·S type

F_w 35–42 mm

Boundary dimensions	Basic load rating		Fatigue load limit N C_u	Allowable speed		Number	Mass kg (approx.)	
	dynamic C_r	static C_{0r}		min ⁻¹ Grease lubrication	Oil lubrication			
mm F_w E_w B_c								
35	42 20	26 500	40 500	4 950	7 500	11 000	KV35×42×20SV2	0.040
	42 30	39 500	68 000	8 300	7 500	11 000	K35×42×30	0.062
36	42 45	42 500	74 000	9 000	7 500	11 000	K35×42×45ZW	0.106
	42 46	51 000	106 000	12 900	7 500	11 000	K36×42×46ZW	0.086
37	42 13	15 900	27 100	3 300	7 500	11 000	K37×42×13V4	0.021
	42 17	21 000	38 500	4 700	7 500	11 000	K37×42×17V2	0.026
	43 33.5	39 000	76 000	9 250	7 500	11 000	KV37×43×33.3XS	0.062
	44 18	26 300	41 000	5 000	7 500	11 000	K37×44×18	0.042
	45 25	37 000	58 000	7 050	7 500	11 000	K37×45×24.8XT2	0.039
38	43 17	20 900	38 500	4 700	7 500	11 000	8E-K38×43×17	0.027
	43 27	32 000	67 500	8 250	7 500	11 000	K38×43×27	0.043
	43 29	32 500	68 000	8 300	7 500	11 000	K38×43×28.8X	0.047
46 32	54 000	95 500	11 600	7 500	11 000	K38×46×32	0.073	
40	45 13	16 500	29 200	3 550	6 500	10 000	K40×45×13V2	0.023
	45 17	21 800	41 500	5 100	6 500	10 000	K40×45×17T	0.027
	45 21	26 700	54 000	6 600	6 500	10 000	K40×45×21V2	0.035
	45 27	33 500	72 500	8 850	6 500	10 000	K40×45×27	0.044
	46 17	24 600	43 000	5 200	6 500	10 000	K40×46×17	0.030
	46 34	40 500	80 500	9 850	6 500	10 000	KV40×46×33.8XS	0.063
	47 18	27 700	45 000	5 450	6 500	10 000	K40×47×18	0.045
	47 20	31 000	51 500	6 300	6 500	10 000	K40×47×20	0.048
	48 20	33 000	51 000	6 250	6 500	10 000	K40×48×20	0.052
	48 25	41 000	68 000	8 300	6 500	10 000	KV40×48×25SV1	0.065
41	49 22	30 500	46 000	5 650	6 500	9 500	8E-KV41×49×21.8XS	0.065
42	47 17	22 100	43 000	5 250	6 500	9 500	K42×47×17	0.028
	47 27	34 000	75 500	9 200	6 500	9 500	K42×47×27	0.047
	48 17	25 700	46 000	5 650	6 500	9 500	K42×48×17	0.036
	50 20	34 000	53 500	6 550	6 500	9 500	K42×50×20	0.054

Note: Bearings may be delivered with a different cage type even if they are ordered by the bearing numbers in the table.

Needle Roller Bearings

Needle roller and cage assemblies

- K type
- K·T2 type
- K·ZW type
- KV·S type
- KVS·ZWS type

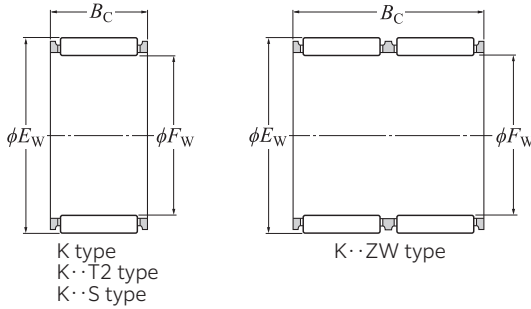

Needle Roller Bearings

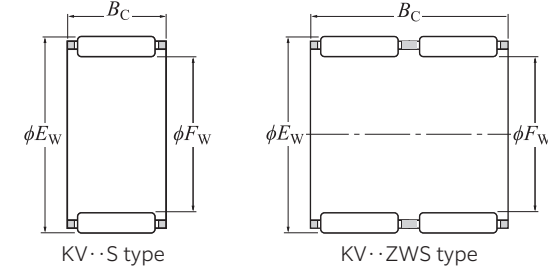

F_w 43–50 mm

Boundary dimensions	Basic load rating		Fatigue load limit N C_u	Allowable speed		Number	Mass kg (approx.)		
	mm			min^{-1}					
	F_w	E_w		Grease lubrication	Oil lubrication				
43	48	17	22 000	43 000	5 250	6 500	9 500	K43×48×17	0.029
	48	27	34 000	75 500	9 200	6 500	9 500	K43×48×27	0.046
	48	38	41 000	96 000	11 700	6 500	9 500	KV43×48×37.8XZWS	0.058
	50	18	29 100	49 000	5 950	6 500	9 500	K43×50×18	0.049
44	50	31	43 500	91 500	11 100	6 500	9 500	KV44×50×30.8XS	0.067
45	49	19	22 100	52 000	6 350	6 000	9 000	K45×49×19	0.027
	50	17	22 300	44 500	5 450	6 000	9 000	K45×50×17V3	0.033
	50	25.8	30 500	66 500	8 100	6 000	9 000	KV45×50×25.8XS	0.045
	50	27	34 500	78 000	9 500	6 000	9 000	K45×50×27	0.050
	51	27	34 500	68 000	8 300	6 000	9 000	KV45×51×26.8XS	0.058
	52	18	29 700	51 000	6 200	6 000	9 000	K45×52×18	0.051
	52	21	32 000	56 500	6 900	6 000	9 000	K45×52×21	0.061
	53	20	36 000	59 000	7 200	6 000	9 000	K45×53×20	0.062
47	52	15.5	19 400	38 000	4 650	5 500	8 500	8E-K47×52×15.3X2	0.031
	52	17	23 200	47 500	5 800	5 500	8 500	K47×52×17	0.033
	52	23	29 600	65 500	7 950	5 500	8 500	KV47×52×22.8X2S	0.044
	52	24	33 500	76 500	9 350	5 500	8 500	K47×52×23.8X	0.044
	52	27	35 500	83 000	10 100	5 500	8 500	K47×52×27	0.051
	52	33	38 000	90 500	11 100	5 500	8 500	KV47×52×32.8XZWS	0.064
48	53	22.5	31 000	69 500	8 450	5 500	8 500	KV48×53×22.3XS	0.042
	53	26	36 500	86 500	10 600	5 500	8 500	K48×53×25.8X3T2	0.029
	53	30	36 500	85 500	10 400	5 500	8 500	K48×53×29.8X1	0.062
	53	37	45 000	112 000	13 700	5 500	8 500	KV48×53×36.8XZWS	0.064
	53	37.5	41 500	101 000	12 300	5 500	8 500	K48×53×37.5ZW	0.072
	54	19	31 000	61 000	7 450	5 500	8 500	K48×54×19	0.044
50	55	13.5	18 100	35 500	4 300	5 500	8 000	K50×55×13.5T	0.023
	55	20	27 900	62 000	7 550	5 500	8 000	KV50×55×20S	0.040

Note: Bearings may be delivered with a different cage type even if they are ordered by the bearing numbers in the table.

F_w 50–60 mm

Boundary dimensions	Basic load rating		Fatigue load limit N C_u	Allowable speed		Number	Mass kg (approx.)		
	mm			min^{-1}					
	F_w	E_w		Grease lubrication	Oil lubrication				
50	55	27	37 000	88 500	10 800	5 500	8 000	K50×55×27	0.053
	55	30	39 500	97 000	11 800	5 500	8 000	K50×55×30	0.059
	57	18	31 500	57 000	6 950	5 500	8 000	K50×57×18	0.053
	58	20	38 500	67 500	8 200	5 500	8 000	K50×58×20	0.065
	58	25	48 500	90 000	11 000	5 500	8 000	K50×58×25	0.081
	58	58	83 500	181 000	22 100	5 500	8 000	KV50×58×57.8XZWS	0.188
52	57	18	22 800	48 000	5 850	5 000	7 500	KV52×57×17.8XS	0.037
	57	23	30 500	69 500	8 500	5 000	7 500	KV52×57×22.8X1S	0.048
	58	19	32 000	65 500	7 950	5 000	7 500	K52×58×19	0.048
54	59	23	31 500	73 500	8 950	5 000	7 500	KV54×59×22.8XS	0.049
55	60	17	25 800	58 000	7 050	5 000	7 500	K55×60×17	0.043
	60	20	28 800	66 500	8 100	5 000	7 500	K55×60×20T	0.045
	60	30	42 000	108 000	13 200	5 000	7 500	KV55×60×30S	0.069
	60	37	47 500	127 000	15 500	5 000	7 500	K55×60×36.8X	0.086
	61	19	33 000	69 500	8 450	5 000	7 500	K55×61×19	0.051
	61	20	33 000	69 500	8 450	5 000	7 500	K55×61×20	0.054
	61	30	48 000	113 000	13 700	5 000	7 500	K55×61×30	0.081
	62	18	33 500	63 000	7 700	5 000	7 500	K55×62×18	0.054
	63	20	39 000	70 000	8 500	5 000	7 500	K55×63×20	0.073
	63	25	50 500	97 500	11 900	5 000	7 500	K55×63×25	0.088
56	66	41	90 000	178 000	21 700	5 000	7 500	K55×63×32	0.117
	66	41	90 000	178 000	21 700	5 000	7 500	K56×66×40.8XT2	0.148
57	65	40	66 000	140 000	17 100	4 700	7 000	KV57×65×39.8XZWS	0.145
58	64	19	34 000	73 500	8 950	4 700	7 000	K58×64×19	0.052
60	65	20	29 800	71 500	8 750	4 300	6 500	K60×65×20	0.051
	65	27	40 000	104 000	12 700	4 300	6 500	K60×65×26.8X	0.067
	65	30	43 500	116 000	14 200	4 300	6 500	K60×65×30	0.071
	66	19	33 500	73 500	8 950	4 300	6 500	K60×66×19	0.053
	66	20	33 500	73 500	8 950	4 300	6 500	K60×66×20	0.056

Note: Bearings may be delivered with a different cage type even if they are ordered by the bearing numbers in the table.

Needle Roller Bearings

Needle roller and cage assemblies

- K type
- K·T2 type
- K·ZW type
- KV·S type
- KV·ZWS type

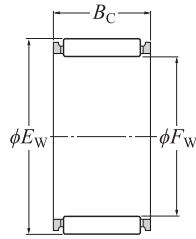

K type
K·T2 type
K·S type

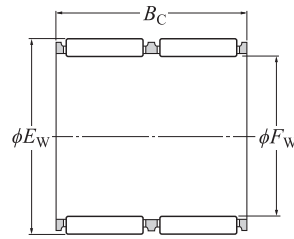

K·ZW type

F_w 60–73 mm

Boundary dimensions			Basic load rating		Fatigue load limit	Allowable speed		Number	Mass
mm			dynamic	static	N C _u	min ⁻¹			kg (approx.)
F_w	E_w	B_c	C_r	C_{0r}		Grease lubrication	Oil lubrication		
60	66	30	49 000	119 000	14 600	4 300	6 500	K60×66×30	0.084
	68	15	27 200	45 500	5 550	4 300	6 500	K60×68×15	0.058
	68	20	40 000	75 000	9 200	4 300	6 500	K60×68×20	0.077
	68	23	44 500	85 000	10 400	4 300	6 500	K60×68×23	0.092
	68	25	52 000	105 000	12 800	4 300	6 500	K60×68×25T	0.097
	68	27	52 000	105 000	12 800	4 300	6 500	K60×68×27	0.098
	68	30	46 500	91 000	11 100	4 300	6 500	K60×68×30ZW	0.119
61	66	20	29 700	71 500	8 750	4 300	6 500	K61×66×20	0.054
	66	30	43 500	116 000	14 200	4 300	6 500	K61×66×30	0.073
63	70	21	44 500	95 500	11 600	4 300	6 500	K63×70×21	0.075
	71	50.5	74 500	167 000	20 400	4 300	6 500	KV63×71×50.3XZWS	0.193
64	70	16	28 400	60 500	7 350	4 300	6 500	K64×70×16	0.053
65	70	20	30 500	75 000	9 150	4 000	6 000	K65×70×20	0.055
	70	21.5	30 500	75 000	9 150	4 000	6 000	KV65×70×21.3X1S	0.056
	70	30	45 000	124 000	15 200	4 000	6 000	K65×70×30	0.083
	73	23	47 000	94 000	11 500	4 000	6 000	K65×73×23	0.100
	73	30	61 000	132 000	16 000	4 000	6 000	K65×73×30	0.126
68	74	20	36 000	83 500	10 200	4 000	6 000	K68×74×20	0.065
	74	30	51 500	133 000	16 200	4 000	6 000	K68×74×30	0.097
	74	35	49 500	125 000	15 300	4 000	6 000	K68×74×35ZW	0.116
	75	21	45 500	101 000	12 300	4 000	6 000	K68×75×21	0.077
70	76	20	36 500	86 000	10 500	3 700	5 500	K70×76×20	0.070
	76	30	53 000	139 000	17 000	3 700	5 500	K70×76×30	0.100
	77	21	45 000	101 000	12 300	3 700	5 500	K70×77×21	0.080
	78	23	49 500	103 000	12 600	3 700	5 500	K70×78×23	0.107
	78	30	65 500	149 000	18 100	3 700	5 500	K70×78×30	0.136
72	79	21	46 500	106 000	12 900	3 700	5 500	K72×79×21	0.085
73	79	20	37 500	90 000	11 000	3 700	5 500	K73×79×20	0.074
	79	30	54 500	146 000	17 800	3 700	5 500	K73×79×30	0.106

Note: Bearings may be delivered with a different cage type even if they are ordered by the bearing numbers in the table.

Needle Roller Bearings

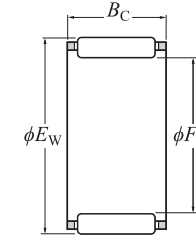

KV·S type

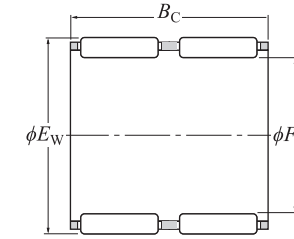

KV·ZWS type

F_w 74–100 mm

Boundary dimensions			Basic load rating		Fatigue load limit	Allowable speed		Number	Mass
mm			dynamic	static	N C _u	min ⁻¹			kg (approx.)
F_w	E_w	B_c	C_r	C_{0r}		Grease lubrication	Oil lubrication		
74	90	50	157 000	287 000	35 000	3 700	5 500	K74×90×49.8XT2	0.380
	81	20	40 000	99 500	12 200	3 700	5 500	KV75×81×19.8X1S	0.071
75	81	30	56 000	152 000	18 600	3 700	5 500	K75×81×30	0.108
	82	21	46 000	106 000	13 000	3 700	5 500	K75×82×21	0.088
	83	23	50 500	109 000	13 300	3 700	5 500	K75×83×23	0.113
	83	30	67 500	157 000	19 200	3 700	5 500	K75×83×30	0.147
80	86	20	39 000	98 000	11 900	3 300	5 000	KV80×86×20SV1	0.077
	86	30	57 000	159 000	19 400	3 300	5 000	K80×86×30	0.110
	88	23	53 000	118 000	14 400	3 300	5 000	K80×88×23	0.125
	88	26	61 000	142 000	17 300	3 300	5 000	K80×88×26	0.131
	88	30	69 000	166 000	20 300	3 300	5 000	K80×88×30	0.157
85	92	30	66 000	176 000	21 500	3 100	4 700	K85×92×30	0.142
	93	27	64 000	153 000	18 700	3 100	4 700	K85×93×27	0.145
	93	30	71 000	175 000	21 400	3 100	4 700	8Q-K85×93×30	0.174
90	97	20	46 000	113 000	13 700	2 900	4 400	K90×97×20	0.103
	97	30	67 500	184 000	22 400	2 900	4 400	K90×97×30	0.151
	98	26	64 000	157 000	19 200	2 900	4 400	K90×98×26	0.148
	98	27	64 000	157 000	19 200	2 900	4 400	K90×98×27	0.150
95	98	30	72 500	184 000	22 400	2 900	4 400	K90×98×30	0.172
	102	21	48 000	122 000	14 900	2 800	4 200	K95×102×21	0.115
	102	31	70 500	199 000	24 300	2 800	4 200	K95×102×31	0.172
100	103	27	65 500	165 000	20 100	2 800	4 200	K95×103×27	0.159
	103	30	74 000	193 000	23 500	2 800	4 200	K95×103×30	0.165
100	107	21	47 500	122 000	14 700	2 700	4 000	KV100×107×21S	0.120
	107	31	71 500	207 000	24 900	2 700	4 000	K100×107×31	0.173
	108	27	61 000	153 000	18 400	2 700	4 000	K100×108×27	0.176
	108	30	76 000	201 000	24 300	2 700	4 000	K100×108×30	0.190

Note: Bearings may be delivered with a different cage type even if they are ordered by the bearing numbers in the table.

Needle Roller Bearings

NTN

Needle roller and cage assemblies

K type
K·L1 type

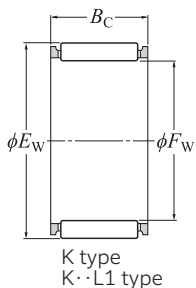

F_w 105–170 mm

Boundary dimensions			Basic load rating		Fatigue load limit N C_u	Allowable speed		Number	Mass kg (approx.)	
mm			dynamic	static		min^{-1}				
F_w	E_w	B_c	C_r	C_{0r}	Grease lubrication	Oil lubrication				
105	112	21	-0.3 -0.65	48 500	127 000	15 100	2 500	3 800	K105×112×21	0.130
	112	31		71 000	207 000	24 600	2 500	3 800	K105×112×31	0.176
	113	30		77 500	210 000	25 000	2 500	3 800	K105×113×30	0.198
110	117	24	-0.3 -0.65	54 500	149 000	17 500	2 400	3 600	K110×117×24	0.145
	117	34		77 500	235 000	27 600	2 400	3 600	K110×117×34	0.205
	118	30		79 000	219 000	25 700	2 400	3 600	K110×118×30	0.217
115	123	27	-0.3 -0.65	64 000	170 000	19 700	2 300	3 500	K115×123×27	0.200
	125	34		95 000	241 000	27 800	2 300	3 500	K115×125×34	0.330
120	127	24	-0.3 -0.65	57 500	165 000	18 900	2 200	3 300	K120×127×24	0.160
	127	34		82 000	260 000	29 800	2 200	3 300	K120×127×34	0.235
125	133	35	-0.3 -0.65	87 000	260 000	29 300	2 100	3 200	K125×133×35	0.275
	135	34		100 000	265 000	29 800	2 100	3 200	K125×135×34	0.350
130	137	24	-0.3 -0.65	59 000	175 000	19 600	2 100	3 100	K130×137×24	0.170
	137	34		84 500	277 000	31 000	2 100	3 100	K130×137×34	0.240
135	143	35	-0.3 -0.65	92 500	288 000	32 000	2 000	3 000	K135×143×35L1	0.313
	150	38		145 000	325 000	36 000	2 000	3 000	K135×150×38	0.590
145	153	26	-0.3 -0.65	72 000	214 000	23 100	1 900	2 800	K145×153×26	0.250
	153	28		80 500	247 000	26 700	1 900	2 800	K145×153×28	0.252
	153	36		100 000	325 000	35 000	1 900	2 800	K145×153×36	0.335
150	160	46	-0.3 -0.65	149 000	470 000	50 500	1 800	2 700	K150×160×46	0.550
115	163	26	-0.3 -0.65	73 500	224 000	23 800	1 700	2 600	K155×163×26	0.270
	163	36		102 000	340 000	36 000	1 700	2 600	K155×163×36	0.355
160	170	46	-0.3 -0.65	155 000	505 000	53 000	1 700	2 500	K160×170×46	0.570
165	173	26	-0.3 -0.65	79 000	251 000	26 100	1 600	2 400	K165×173×26	0.290
	173	32		97 000	330 000	34 000	1 600	2 400	K165×173×32	0.340
	173	36		109 000	380 000	39 500	1 600	2 400	K165×173×36	0.375
170	180	46	-0.3 -0.65	160 000	540 000	55 500	1 600	2 400	K170×180×46	0.620

Note: Bearings may be delivered with a different cage type even if they are ordered by the bearing numbers in the table.

Needle Roller Bearings

NTN

F_w 175–285 mm

Boundary dimensions			Basic load rating		Fatigue load limit N C_u	Allowable speed		Number	Mass kg (approx.)	
mm			dynamic	static		min^{-1}				
F_w	E_w	B_c	C_r	C_{0r}	Grease lubrication	Oil lubrication				
175	183	32	-0.3 -0.65	101 000	350 000	36 000	1 500	2 300	K175×183×32L1	0.379
185	195	37	-0.3 -0.65	131 000	425 000	43 000	1 500	2 200	K185×195×37L1	0.581
195	205	37	-0.3 -0.65	135 000	450 000	44 500	1 400	2 100	K195×205×37L1	0.620
210	220	42	-0.3 -0.65	156 000	560 000	54 000	1 300	1 900	K210×220×42	0.740
220	230	42	-0.3 -0.65	161 000	590 000	56 500	1 200	1 800	K220×230×42	0.790
240	250	42	-0.3 -0.65	167 000	635 000	59 000	1 100	1 700	K240×250×42L1	0.849
265	280	50	-0.3 -0.65	256 000	850 000	77 000	1 000	1 500	K265×280×50L1	1.77
285	300	50	-0.3 -0.65	268 000	930 000	82 000	950	1 400	K285×300×50	1.97

Note: Bearings may be delivered with a different cage type even if they are ordered by the bearing numbers in the table.

Needle Roller Bearings

Drawn cup needle roller bearings

HK type, HK · ZWD type
HMK type
BK type, BK · ZWD type

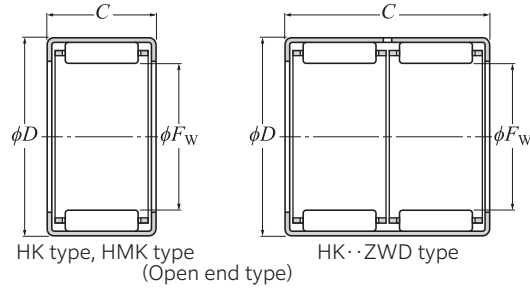

Needle Roller Bearings

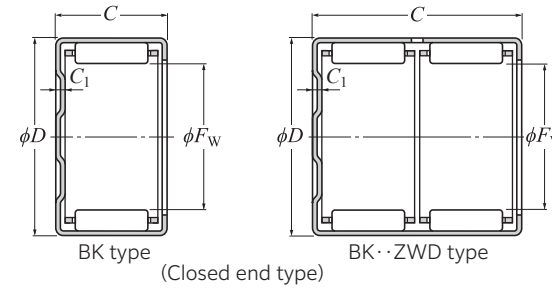

F_w 3–10 mm

F_w	Boundary dimensions mm		Basic load rating		Fatigue load limit N C_u	Allowable speed		Number		Mass kg (approx.)	Applied inner ring ¹⁾ (approx.)	
	D	C	C ₁	dynamic N C_r		static N C_{0r}	min ⁻¹ Grease lubrication	Oil lubrication	Open end type			Closed end type
3	6.5	6	—	925	565	69	33 000	50 000	HK0306FT2	—	0.0006	—
	6.5	6	0.8	925	565	69	33 000	50 000	—	BK0306T2	0.0007	—
4	8	8	—	1 770	1 270	155	30 000	45 000	HK0408FT2	—	0.0016	—
	8	8	1.6	1 770	1 270	155	30 000	45 000	—	BK0408T2	0.0018	—
5	9	9	—	2 450	1 990	243	27 000	40 000	HK0509FM	—	0.0019	—
	9	9	1.6	2 450	1 990	243	27 000	40 000	—	BK0509	0.0021	—
6	10	9	—	2 920	2 590	315	25 000	37 000	HK0609FM	—	0.0022	—
	10	9	1.6	2 660	2 280	278	25 000	37 000	—	BK0609T2	0.0024	—
7	11	9	—	3 150	2 930	355	23 000	34 000	HK0709FM	—	0.0025	—
	11	9	1.6	3 150	2 930	355	23 000	34 000	—	BK0709CT	0.0027	—
8	12	10	—	3 850	3 950	480	20 000	30 000	HK0810FM	—	0.0032	IR 5 × 8 × 12
	12	10	1.6	3 850	3 950	480	20 000	30 000	—	BK0810CT	0.0034	IR 5 × 8 × 12
	15	10	—	4 200	3 300	400	20 000	30 000	HMK0810CT	—	0.0067	IR 5 × 8 × 12
	15	15	—	7 300	6 650	770	20 000	30 000	HMK0815CT	—	0.010	IR 5 × 8 × 16
	15	20	—	9 050	8 750	1 070	20 000	30 000	HMK0820T2	—	0.013	—
9	13	10	—	4 300	4 650	570	18 000	27 000	HK0910FM	—	0.0035	IR 6 × 9 × 12
	13	10	1.6	4 300	4 650	570	18 000	27 000	—	BK0910CT	0.0039	IR 6 × 9 × 12
	13	12	—	5 400	6 250	765	18 000	27 000	HK0912F	—	0.0042	IR 6 × 9 × 12
	13	12	1.6	5 400	6 250	765	18 000	27 000	—	BK0912CT	0.0045	IR 6 × 9 × 12
	16	12	—	5 300	4 450	545	18 000	27 000	HMK0912	—	0.0087	IR 6 × 9 × 16
	16	16	—	7 400	6 850	840	18 000	27 000	HMK0916	—	0.012	—
10	14	10	—	4 500	5 100	620	16 000	24 000	HK1010FM	—	0.0038	IR 7 × 10 × 10.5
	14	10	1.6	4 500	5 100	620	16 000	24 000	—	BK1010	0.0042	IR 7 × 10 × 10.5
	14	12	—	5 650	6 800	830	16 000	24 000	HK1012F	—	0.0045	IR 7 × 10 × 16
	14	12	1.6	5 900	7 250	880	16 000	24 000	—	BK1012	0.0050	IR 7 × 10 × 16
	14	15	—	7 250	9 400	1 140	16 000	24 000	HK1015F	—	0.0056	IR 7 × 10 × 16
	14	15	1.6	7 250	9 400	1 140	16 000	24 000	—	BK1015CT	0.0062	IR 7 × 10 × 16
	17	10	—	4 250	3 450	420	16 000	24 000	HMK1010	—	0.0079	IR 7 × 10 × 10.5
	17	12	—	5 600	4 850	590	16 000	24 000	HMK1012	—	0.0094	IR 7 × 10 × 16

1) If the bearing has an inner ring, the value indicates HK + IR.
Example: HK1012F + IR7 × 10 × 16

F_w 10–15 mm

F_w	Boundary dimensions mm		Basic load rating		Fatigue load limit N C_u	Allowable speed		Number		Mass kg (approx.)	Applied inner ring ¹⁾ (approx.)	
	D	C	C ₁	dynamic N C_r		static N C_{0r}	min ⁻¹ Grease lubrication	Oil lubrication	Open end type			Closed end type
10	17	15	—	7 400	6 950	850	16 000	24 000	HMK1015	—	0.012	IR 7 × 10 × 16
	17	20	—	9 900	10 100	1 240	16 000	24 000	7E-HMK1020CT	—	0.016	—
12	16	10	—	5 050	6 250	760	13 000	20 000	HK1210FM	—	0.0046	IR 8 × 12 × 10.5
	16	10	1.6	5 050	6 250	760	13 000	20 000	—	BK1210	0.0052	IR 8 × 12 × 10.5
	18	12	—	6 600	7 300	890	13 000	20 000	HK1212FM	—	0.0091	IR 8 × 12 × 12.5
	18	12	2.7	6 600	7 300	890	13 000	20 000	—	BK1212	0.010	IR 8 × 12 × 12.5
	19	12	—	7 100	6 900	845	13 000	20 000	HMK1212	—	0.011	IR 8 × 12 × 12.5
	19	15	—	9 400	9 900	1 210	13 000	20 000	7E-HMK1215C	—	0.014	IR 9 × 12 × 16
	19	20	—	12 900	14 900	1 820	13 000	20 000	HMK1220CT	—	0.018	—
13	19	12	—	6 950	7 900	965	12 000	18 000	HK1312FM	—	0.010	IR10 × 13 × 12.5
	19	12	2.7	6 950	7 900	965	12 000	18 000	—	BK1312	0.011	IR10 × 13 × 12.5
14	20	12	—	7 200	8 500	1 040	11 000	17 000	HK1412FM	—	0.011	IR10 × 14 × 13
	20	12	2.7	7 200	8 500	1 040	11 000	17 000	—	BK1412	0.012	IR10 × 14 × 13
	20	16	—	10 300	13 400	1 640	11 000	17 000	HK1416F	—	0.015	—
	20	16	2.7	10 300	13 400	1 640	11 000	17 000	—	BK1416CT	0.016	—
	22	16	—	11 500	12 000	1 460	11 000	17 000	HMK1416C	—	0.019	IR10 × 14 × 20
	22	20	—	14 600	16 200	1 980	11 000	17 000	HMK1420C	—	0.024	—
15	21	12	—	7 500	9 100	1 110	11 000	16 000	HK1512FM	—	0.011	IR12 × 15 × 12.5
	21	12	2.7	7 500	9 100	1 110	11 000	16 000	—	BK1512	0.013	IR12 × 15 × 12.5
	21	16	—	10 700	14 400	1 750	11 000	16 000	HK1516F	—	0.015	IR12 × 15 × 16.5
	21	16	2.7	10 700	14 400	1 750	11 000	16 000	—	BK1516	0.017	IR12 × 15 × 16.5
	21	22	—	12 900	18 200	2 220	11 000	16 000	HK1522ZWFD	—	0.020	IR12 × 15 × 22.5
	21	22	2.7	12 900	18 200	2 220	11 000	16 000	—	BK1522ZWD	0.022	IR12 × 15 × 22.5
	22	10	—	6 100	6 000	730	11 000	16 000	HMK1510	—	0.011	IR10 × 15 × 12.5
	22	12	—	7 950	8 450	1 030	11 000	16 000	HMK1512	—	0.013	IR12 × 15 × 12.5
	22	15	—	10 500	12 100	1 480	11 000	16 000	HMK1515C	—	0.016	IR12 × 15 × 16
	22	20	—	15 300	19 700	2 400	11 000	16 000	HMK1520CV6	—	0.022	IR12 × 15 × 22.5
22	25	—	18 500	25 000	3 050	11 000	16 000	HMK1525	—	0.027	—	

1) If the bearing has an inner ring, the value indicates HK + IR.
Example: HK1312FM + IR10 × 13 × 12.5

Needle Roller Bearings

Drawn cup needle roller bearings

HK type, HK · ZWD type
HMK type
BK type, BK · ZWD type

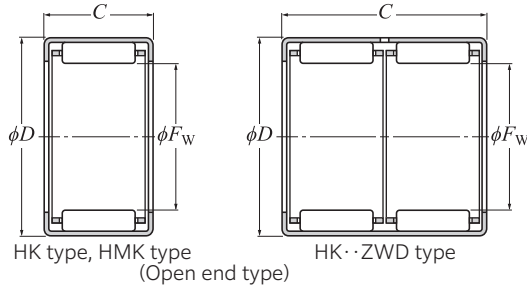

Needle Roller Bearings

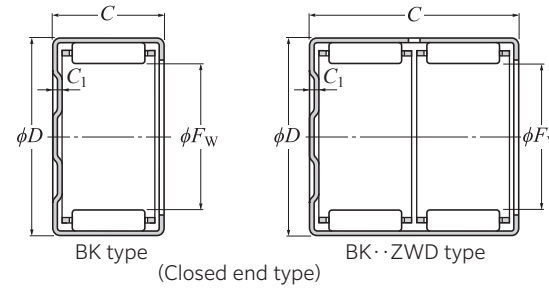

F_w 16–20 mm

Boundary dimensions mm	C	C_1	Basic load rating		Fatigue load limit N C_u	Allowable speed		Number	Mass kg (approx.)	Applied inner ring ¹⁾ (approx.)		
			dynamic	static		min ⁻¹	Open end type				Closed end type	
												C_r
F_w	D	-0.2	Max.	C_r	C_{0r}	N	C_u					
16	22	12	—	7 750	9 700	1 180	10 000	15 000	HK1612FM	—	0.012	IR12×16×13
	22	12	2.7	7 750	9 700	1 180	10 000	15 000	—	BK1612	0.014	IR12×16×13
	22	16	—	11 100	15 300	1 870	10 000	15 000	HK1616F	—	0.016	IR12×16×20
	22	16	2.7	11 100	15 300	1 870	10 000	15 000	—	BK1616	0.018	IR12×16×20
	22	22	—	13 300	19 400	2 370	10 000	15 000	HK1622ZWF	—	0.022	—
	22	22	2.7	13 300	19 400	2 370	10 000	15 000	—	BK1622ZWD	0.023	—
	24	16	—	12 400	13 500	1 640	10 000	15 000	HMK1616	—	0.021	IR12×16×20
	24	20	—	15 600	18 200	2 220	10 000	15 000	7E-HMK1620CT	—	0.027	IR12×16×22
17	23	12	—	8 050	10 300	1 260	9 500	14 000	HK1712FM	—	0.012	—
	23	12	2.7	8 050	10 300	1 260	9 500	14 000	—	BK1712CT	0.015	—
	24	15	—	11 600	14 200	1 740	9 500	14 000	7E-HMK1715CT	—	0.018	IR14×17×17
	24	20	—	15 200	20 000	2 440	9 500	14 000	7E-HMK1720CT	—	0.024	IR12×17×20.5
	24	25	—	19 000	26 700	3 250	9 500	14 000	7E-HMK1725CT	—	0.030	IR12×17×25.5
18	24	12	—	8 300	10 900	1 330	8 500	13 000	HK1812FM	—	0.013	IR15×18×12.5
	24	12	2.7	8 300	10 900	1 330	8 500	13 000	—	BK1812	0.015	IR15×18×12.5
	24	16	—	11 800	17 300	2 110	8 500	13 000	HK1816F	—	0.018	IR15×18×16.5
	24	16	2.7	11 800	17 300	2 110	8 500	13 000	—	BK1816	0.020	IR15×18×16.5
	25	13	—	10 200	12 200	1 480	8 500	13 000	HMK1813	—	0.016	IR15×18×16
	25	15	—	12 000	15 100	1 840	8 500	13 000	HMK1815	—	0.019	IR15×18×16
	25	17	—	13 300	17 200	2 100	8 500	13 000	HMK1817C	—	0.021	IR15×18×17.5
	25	19	—	15 500	20 900	2 540	8 500	13 000	HMK1819	—	0.024	IR15×18×20.5
	25	20	—	16 300	22 300	2 720	8 500	13 000	HMK1820	—	0.025	IR15×18×20.5
	25	25	—	20 900	31 000	3 750	8 500	13 000	HMK1825V2	—	0.031	IR15×18×25.5
19	27	16	—	13 900	16 300	2 000	8 500	13 000	HMK1916	—	0.025	IR15×19×20
	27	20	—	18 100	23 000	2 800	8 500	13 000	HMK1920F	—	0.031	—
20	26	12	—	8 750	12 100	1 480	8 000	12 000	HK2012FM	—	0.014	IR15×20×13
	26	12	2.7	9 250	13 000	1 590	8 000	12 000	—	BK2012	0.017	IR15×20×13
	26	16	—	12 500	19 200	2 340	8 000	12 000	HK2016F	—	0.019	IR17×20×16.5
	26	16	2.7	13 000	20 100	2 450	8 000	12 000	—	BK2016	0.022	IR17×20×16.5
	26	20	—	16 000	26 200	3 200	8 000	12 000	HK2020F	—	0.024	IR17×20×20.5

1) If the bearing has an inner ring, the value indicates HK + IR.
Example: HK1812FM+IR15×18×12.5

F_w 20–25 mm

Boundary dimensions mm	C	C_1	Basic load rating		Fatigue load limit N C_u	Allowable speed		Number	Mass kg (approx.)	Applied inner ring ¹⁾ (approx.)		
			dynamic	static		min ⁻¹	Open end type				Closed end type	
												C_r
F_w	D	-0.2	Max.	C_r	C_{0r}	N	C_u					
20	26	20	2.7	16 000	26 200	3 200	8 000	12 000	—	BK2020CT	0.027	IR17×20×20.5
	26	30	—	21 500	38 500	4 700	8 000	12 000	HK2030ZWF	—	0.035	IR17×20×30.5
	26	30	2.7	22 200	40 000	4 900	8 000	12 000	—	BK2030ZWD	0.037	IR17×20×30.5
	27	15	—	13 000	17 300	2 110	8 000	12 000	HMK2015CV3	—	0.021	IR17×20×16.5
	27	20	—	17 200	24 800	3 000	8 000	12 000	HMK2020CT	—	0.027	IR17×20×20.5
	27	25	—	22 000	34 000	4 150	8 000	12 000	HMK2025C	—	0.034	IR15×20×26
	27	30	—	26 100	42 000	5 150	8 000	12 000	HMK2030	—	0.041	IR17×20×30.5
	21	29	16	—	15 300	19 100	2 320	7 500	11 000	HMK2116	—	0.027
29		20	—	19 400	25 800	3 150	7 500	11 000	HMK2120	—	0.033	—
22	28	12	—	9 200	13 400	1 630	7 500	11 000	HK2212FM	—	0.013	IR17×22×13
	28	12	2.7	9 200	13 400	1 630	7 500	11 000	—	BK2212CT	0.015	IR17×22×13
	28	16	—	13 200	21 100	2 570	7 500	11 000	HK2216F	—	0.021	IR17×22×18
	28	16	2.7	13 600	22 100	2 700	7 500	11 000	—	BK2216	0.024	IR17×22×18
	28	20	—	16 800	28 800	3 500	7 500	11 000	HK2220F	—	0.026	IR17×22×20.5
	28	20	2.7	17 200	29 800	3 650	7 500	11 000	—	BK2220	0.030	IR17×22×20.5
	29	10	—	8 400	10 100	1 240	7 500	11 000	HMK2210	—	0.015	IR17×22×13
	29	15	—	12 900	17 600	2 150	7 500	11 000	7E-HMK2215C	—	0.022	IR17×22×16D
	29	20	—	18 200	27 400	3 350	7 500	11 000	HMK2220CV2	—	0.030	IR17×22×20.5
	29	25	—	23 200	37 500	4 550	7 500	11 000	HMK2225CT	—	0.037	IR17×22×26
29	30	—	26 900	45 000	5 500	7 500	11 000	HMK2230	—	0.045	IR17×22×32	
24	31	20	—	18 300	28 200	3 450	6 500	10 000	HMK2420CT	—	0.032	—
	31	28	—	26 000	44 500	5 400	6 500	10 000	HMK2428	—	0.045	IR20×24×28.5
25	32	12	—	11 100	15 200	1 850	6 500	9 500	HK2512F	—	0.021	IR20×25×12.5
	32	12	2.7	11 800	16 300	1 990	6 500	9 500	—	BK2512	0.023	IR20×25×12.5
	32	16	—	15 900	24 000	2 920	6 500	9 500	HK2516F	—	0.027	IR20×25×17
	32	16	2.7	15 900	24 000	2 920	6 500	9 500	—	BK2516	0.031	IR20×25×17
	32	20	—	20 300	33 000	4 000	6 500	9 500	HK2520	—	0.034	IR20×25×20.5
	32	20	2.7	20 300	33 000	4 000	6 500	9 500	—	BK2520	0.039	IR20×25×20.5
	32	26	—	26 400	46 000	5 600	6 500	9 500	HK2526C	—	0.045	IR20×25×26.5
	32	26	2.7	26 400	46 000	5 600	6 500	9 500	—	BK2526C	0.049	IR20×25×26.5

1) If the bearing has an inner ring, the value indicates HK + IR.
Example: HK2512F + IR20 × 25 × 12.5

Needle Roller Bearings

Drawn cup needle roller bearings

HK type, HK·ZWD type
HMK type, HMK·ZWD type
BK type, BK·ZWD type

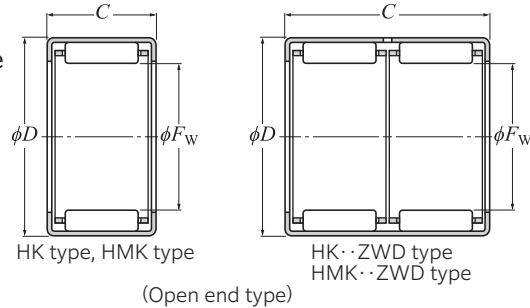

(Open end type)

F_w 25-30 mm

F_w	Boundary dimensions mm		Basic load rating		Fatigue load limit N C_u	Allowable speed		Number		Mass kg (approx.)	Applied inner ring ¹⁾ (approx.)	
	C	C ₁	dynamic N C _r	static N C _{0r}		min ⁻¹		Open end type	Closed end type			
						Grease lubrication	Oil lubrication					
25	32	38	—	35 000	65 500	8 000	6 500	9 500	HK2538ZWD	—	0.065	IR20×25×38.5
	32	38	2.7	35 000	65 500	8 000	6 500	9 500	—	BK2538ZWD	0.069	IR20×25×38.5
	33	10	—	9 150	10 400	1 270	6 500	9 500	HMK2510	—	0.019	IR20×25×12.5
	33	15	—	15 200	19 900	2 430	6 500	9 500	HMK2515CT	—	0.029	IR20×25×16
	33	20	—	21 200	30 500	3 750	6 500	9 500	HMK2520CT	—	0.039	IR20×25×20.5
	33	25	—	26 700	41 000	5 000	6 500	9 500	HMK2525F	—	0.048	IR20×25×26.5
	33	30	—	32 000	52 000	6 350	6 500	9 500	7E-HMK2530C	—	0.058	IR20×25×32
	26	34	16	—	17 100	23 400	2 860	6 000	9 000	7E-HMK2616	—	0.032
34		20	—	21 100	30 500	3 750	6 000	9 000	7E-HMK2620CT	—	0.040	—
28	35	16	—	16 700	26 400	3 200	5 500	8 500	HK2816CT	—	0.030	IR22×28×17
	35	16	2.7	16 700	26 400	3 200	5 500	8 500	—	BK2816CT	0.034	IR22×28×17
	35	20	—	21 300	36 000	4 400	5 500	8 500	HK2820	—	0.038	IR22×28×20.5
	35	20	2.7	21 300	36 000	4 400	5 500	8 500	—	BK2820	0.043	IR22×28×20.5
	37	20	—	23 600	32 500	4 000	5 500	8 500	HMK2820	—	0.049	IR22×28×20.5
	37	30	—	35 000	54 500	6 600	5 500	8 500	7E-HMK2830C	—	0.073	—
29	38	20	—	24 600	35 000	4 250	5 500	8 500	HMK2920	—	0.050	—
	38	30	—	34 500	54 000	6 600	5 500	8 500	HMK2930	—	0.075	—
30	37	12	—	12 300	18 200	2 220	5 500	8 000	HK3012CT	—	0.024	IR25×30×12.5
	37	12	2.7	12 300	18 200	2 220	5 500	8 000	—	BK3012CT	0.028	IR25×30×12.5
	37	16	—	18 100	30 000	3 650	5 500	8 000	7E-HK3016C	—	0.032	IR25×30×17
	37	16	2.7	18 100	30 000	3 650	5 500	8 000	—	BK3016CT	0.037	IR25×30×17
	37	20	—	22 300	39 500	4 800	5 500	8 000	HK3020F	—	0.040	IR25×30×20.5
	37	20	2.7	22 300	39 500	4 800	5 500	8 000	—	BK3020	0.047	IR25×30×20.5
	37	26	—	28 500	54 000	6 550	5 500	8 000	HK3026F	—	0.053	IR25×30×26.5
	37	26	2.7	28 500	54 000	6 550	5 500	8 000	—	7E-BK3026T	0.059	IR25×30×26.5
	37	38	—	38 500	78 500	9 600	5 500	8 000	HK3038ZWD	—	0.076	IR25×30×38.5
	37	38	2.7	38 500	78 500	9 600	5 500	8 000	—	BK3038ZWD	0.083	IR25×30×38.5
	40	13	—	14 100	17 100	2 090	5 500	8 000	HMK3013	—	0.040	IR25×30×16
	40	15	—	17 100	22 100	2 690	5 500	8 000	HMK3015	—	0.044	IR25×30×16
40	20	—	24 200	34 500	4 200	5 500	8 000	HMK3020	—	0.058	IR25×30×20.5	

1) If the bearing has an inner ring, the value indicates HK + IR.
Example: HK2820 + IR22×28×20.5

Needle Roller Bearings

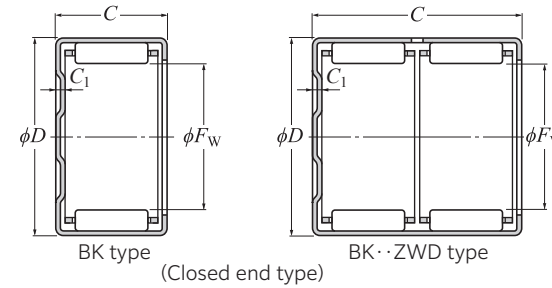

(Closed end type)

F_w 30-40 mm

F_w	Boundary dimensions mm		Basic load rating		Fatigue load limit N C_u	Allowable speed		Number		Mass kg (approx.)	Applied inner ring ¹⁾ (approx.)	
	C	C ₁	dynamic N C _r	static N C _{0r}		min ⁻¹		Open end type	Closed end type			
						Grease lubrication	Oil lubrication					
30	40	25	—	31 000	47 500	5 800	5 500	8 000	7E-HMK3025CT	—	0.073	IR25×30×26.5
	40	30	—	36 000	57 500	7 000	5 500	8 000	HMK3030	—	0.087	IR25×30×32
32	42	20	—	27 500	38 000	4 600	5 000	7 500	7E-HMK3220	—	0.062	—
	42	30	—	41 500	64 500	7 850	5 000	7 500	7E-HMK3230	—	0.092	—
35	42	12	—	13 300	21 300	2 600	4 700	7 000	HK3512CV2	—	0.028	—
	42	12	2.7	13 300	21 300	2 600	4 700	7 000	—	BK3512CT	0.033	—
	42	16	—	19 000	33 500	4 100	4 700	7 000	HK3516CT	—	0.037	—
	42	16	2.7	19 000	33 500	4 100	4 700	7 000	—	BK3516CT	0.044	—
	42	20	—	24 800	47 500	5 800	4 700	7 000	HK3520	—	0.046	—
	42	20	2.7	24 800	47 500	5 800	4 700	7 000	—	BK3520	0.055	—
	45	12	—	14 900	17 600	2 150	4 700	7 000	HMK3512	—	0.040	—
	45	15	—	20 200	26 200	3 200	4 700	7 000	HMK3515	—	0.050	—
	45	20	—	28 400	40 500	4 900	4 700	7 000	7E-HMK3520B	—	0.067	—
	45	25	—	36 000	54 500	6 650	4 700	7 000	HMK3525	—	0.083	—
37	47	20	—	29 300	43 000	5 250	4 300	6 500	HMK3720	—	0.070	—
	47	30	—	44 500	73 000	8 900	4 300	6 500	HMK3730	—	0.105	—
38	48	15	—	21 700	29 300	3 550	4 300	6 500	HMK3815	—	0.054	—
	48	20	—	30 500	45 000	5 500	4 300	6 500	HMK3820	—	0.072	—
	48	25	—	38 500	61 000	7 450	4 300	6 500	HMK3825	—	0.090	—
	48	30	—	46 000	77 000	9 400	4 300	6 500	HMK3830	—	0.107	IR32×38×32
	48	45	—	62 000	113 000	13 700	4 300	6 500	HMK3845ZWD	—	0.161	—
40	47	12	—	12 100	19 500	2 380	4 000	6 000	HK4012V2	—	0.031	IR35×40×12.5
	47	12	2.7	12 600	20 800	2 530	4 000	6 000	—	7E-BK4012CT	0.038	IR35×40×12.5
	47	16	—	20 300	38 500	4 700	4 000	6 000	HK4016CT	—	0.041	IR35×40×17
	47	16	2.7	20 300	38 500	4 700	4 000	6 000	—	BK4016CT	0.051	IR35×40×17
	47	20	—	25 900	52 500	6 400	4 000	6 000	HK4020F	—	0.052	IR35×40×20.5
	47	20	2.7	25 900	52 500	6 400	4 000	6 000	—	BK4020	0.064	IR35×40×20.5
	50	15	—	23 100	32 500	3 950	4 000	6 000	HMK4015	—	0.056	IR35×40×17
	50	20	—	32 500	50 000	6 100	4 000	6 000	7E-HMK4020	—	0.075	IR35×40×20.5

1) If the bearing has an inner ring, the value indicates HK + IR.
Example: HK4012 + IR35×40×12.5

Needle Roller Bearings

NTN

Drawn cup needle roller bearings

HK type
HMK type, HMK··ZWD type
BK type

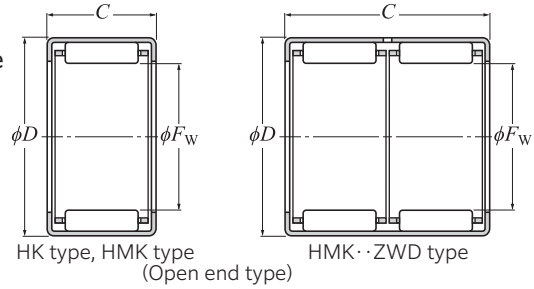

Needle Roller Bearings

NTN

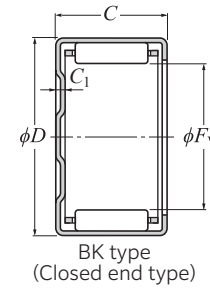

F_w 40–50 mm

Boundary dimensions mm	Basic load rating		Fatigue load limit N C_u	Allowable speed		Number		Mass kg (approx.)	Applied inner ring ¹⁾ (approx.)			
	dynamic N C_r	static N C_{0r}		min ⁻¹ Grease lubrication	Oil lubrication	Open end type	Closed end type					
F_w	C 0	C_1 Max.										
	-0.2											
40	50	25	—	41 000	67 500	8 250	4 000	6 000	7E-HMK4025	—	—	
	50	30	—	49 000	85 000	10 400	4 000	6 000	HMK4030	—	IR35×40×34	
	50	40	—	58 500	107 000	13 000	4 000	6 000	HMK4040ZWD	—	—	
45	52	16	—	21 600	43 000	5 250	3 700	5 500	HK4516	—	IR40×45×17	
	52	16	2.7	21 600	43 000	5 250	3 700	5 500	—	BK4516	0.058	IR40×45×17
	52	20	—	27 600	59 000	7 200	3 700	5 500	HK4520	—	IR40×45×20.5	
	52	20	2.7	27 600	59 000	7 200	3 700	5 500	—	BK4520	0.072	IR40×45×20.5
	55	20	—	32 000	51 000	6 200	3 700	5 500	7E-HMK4520CT	—	IR40×45×20.5	
	55	25	—	41 500	71 500	8 700	3 700	5 500	HMK4525	—	IR40×45×26.5	
	55	30	—	49 500	90 000	11 000	3 700	5 500	7E-HMK4530CT	—	IR40×45×34	
	55	40	—	59 500	113 000	13 800	3 700	5 500	HMK4540ZWD	—	—	
50	58	20	—	31 500	63 000	7 700	3 200	4 800	HK5020	—	IR40×50×22	
	58	20	2.7	31 500	63 000	7 700	3 200	4 800	—	BK5020	0.087	IR40×50×22
	58	25	—	38 500	82 000	10 000	3 200	4 800	HK5025	—	IR45×50×25.5	
	58	25	2.7	38 500	82 000	10 000	3 200	4 800	—	BK5025	0.109	IR45×50×25.5
	62	12	—	18 200	23 600	2 880	3 200	4 800	7E-HMK5012	—	—	
	62	15	—	25 900	37 000	4 550	3 200	4 800	7E-HMK5015	—	—	
	62	20	—	37 500	60 000	7 300	3 200	4 800	7E-HMK5020CT	—	IR40×50×22	
	62	25	—	48 000	82 500	10 100	3 200	4 800	7E-HMK5025	—	IR45×50×25.5	
	62	30	—	58 500	105 000	12 800	3 200	4 800	7E-HMK5030CPX1	—	IR45×50×32	
	62	40	—	70 000	134 000	16 300	3 200	4 800	7E-HMK5040ZWD	—	—	
	62	45	—	79 000	156 000	19 100	3 200	4 800	7E-HMK5045ZWCDPX1	—	—	

1) If the bearing has an inner ring, the value indicates HK + IR.
Example: HK4516+IR40×45×17

Needle Roller Bearings

Machined-ring needle roller bearings without an inner ring

RNA49 type
RNA59 type
RNA69 type
NK type

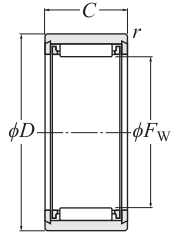

NK type
($\phi F_w \leq 12$ mm)

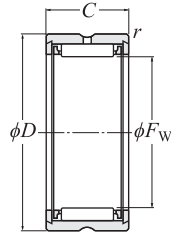

RNA49 type
($\phi F_w \leq 12$ mm)

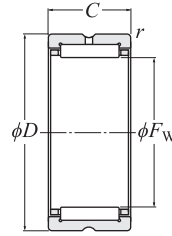

RNA49·R type ($\phi F_w \geq 14$ mm)
RNA59 type
RNA69·R type
NK·R type ($\phi F_w \geq 14$ mm)

F_w 5–16 mm

F_w	Boundary dimensions			Basic load rating		Fatigue load limit N C_u	Allowable speed		Number	Installation-related dimensions		Mass kg (approx.)
	mm			dynamic	static		min^{-1}			mm		
	D	C	$r_s \text{ min}^{-1}$	C_r	C_{0r}		Grease lubrication	Oil lubrication		D_a Max.	$r_{as}^{(2)}$ Max.	
5	+0.018	10	0.15	2 640	2 190	267	27 000	40 000	NK5/10T2	6.5	0.15	0.0031
	+0.010	10	0.15	2 720	2 250	275	27 000	40 000		NK5/12T2	6.5	0.15
6	+0.018	12	0.15	2 660	2 280	278	25 000	37 000	NK6/10T2	7.5	0.15	0.0047
	+0.010	12	0.15	3 400	3 150	380	25 000	37 000		NK6/12T2	7.5	0.15
7	+0.022 +0.013	13	0.15	2 670	2 350	286	23 000	34 000	RNA495T2	8.5	0.15	0.0055
		14	0.3	2 670	2 350	286	23 000	34 000	NK7/10T2	8.5	0.3	0.0069
		14	0.3	3 400	3 200	390	23 000	34 000	NK7/12T2	8.5	0.3	0.0082
8	+0.022 +0.013	15	0.15	3 150	3 000	365	21 000	32 000	RNA496T2T	9.5	0.15	0.0073
		15	0.3	4 000	4 100	500	21 000	32 000	NK8/12T2	9.5	0.3	0.0087
		15	0.3	4 850	5 200	635	21 000	32 000	NK8/16	9.5	0.3	0.012
9	+0.022 +0.013	16	0.3	4 550	5 000	615	20 000	30 000	NK9/12T2	10.5	0.3	0.010
		16	0.3	5 500	6 400	780	20 000	30 000	NK9/16T2	10.5	0.3	0.013
		17	0.15	3 600	3 650	445	20 000	30 000	RNA497	10.5	0.15	0.0095
10	+0.022 +0.013	17	0.3	4 550	5 100	620	19 000	28 000	NK10/12T2	11.5	0.3	0.010
		17	0.3	5 450	6 450	790	19 000	28 000	8E-NK10/16CT	11.5	0.3	0.013
		19	0.15	5 250	5 150	630	19 000	28 000	RNA498CT	12	0.15	0.013
12	+0.027 +0.016	19	0.3	5 000	6 100	740	17 000	26 000	NK12/12	13.5	0.3	0.013
		19	0.3	6 000	7 700	940	17 000	26 000	NK12/16	13.5	0.3	0.016
		20	0.3	4 850	4 900	600	17 000	26 000	RNA499	14	0.3	0.013
14	+0.027 +0.016	22	0.3	8 600	9 200	1 120	16 000	24 000	RNA4900R	20	0.3	0.017
		22	0.3	10 300	11 500	1 400	16 000	24 000	NK14/16RCT	20	0.3	0.021
		22	0.3	13 000	15 600	1 900	16 000	24 000	NK14/20R	20	0.3	0.026
15	+0.027 +0.016	23	0.3	10 900	12 700	1 550	15 000	23 000	NK15/16R	21	0.3	0.022
		23	0.3	13 800	17 200	2 100	15 000	23 000	NK15/20R	21	0.3	0.027
16	+0.027 +0.016	24	0.3	9 550	10 900	1 330	15 000	23 000	RNA4901R	22	0.3	0.017
		24	0.3	12 200	14 900	1 820	15 000	23 000	NK16/16R	22	0.3	0.022
		24	0.3	14 600	18 800	2 290	15 000	23 000	NK16/20R	22	0.3	0.028
		24	0.3	15 400	20 000	2 440	15 000	23 000	RNA6901R	22	0.3	0.031

1) Smallest allowable dimension for chamfer dimension r .
2) Largest allowable dimension for fillet radius r_a of housing and shaft.

Needle Roller Bearings

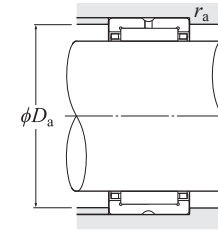
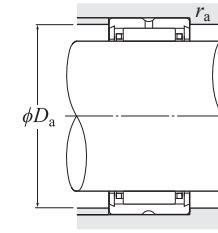

F_w 17–28 mm

F_w	Boundary dimensions			Basic load rating		Fatigue load limit N C_u	Allowable speed		Number	Installation-related dimensions		Mass kg (approx.)	
	mm			dynamic	static		min^{-1}			mm			
	D	C	$r_s \text{ min}^{-1}$	C_r	C_{0r}		Grease lubrication	Oil lubrication		D_a Max.	$r_{as}^{(2)}$ Max.		
17	+0.027	25	0.3	12 100	15 000	1 830	15 000	22 000	NK17/16R	23	0.3	0.024	
	+0.016	25	0.3	15 400	20 400	2 490	15 000	22 000		NK17/20R	23	0.3	0.030
18	+0.027	26	0.3	12 700	16 200	1 980	14 000	21 000	NK18/16R	24	0.3	0.025	
	+0.016	26	0.3	16 100	22 000	2 690	14 000	21 000		NK18/20RCT	24	0.3	0.031
19	+0.033	27	0.3	13 300	17 400	2 120	14 000	21 000	NK19/16R	25	0.3	0.026	
	+0.020	27	0.3	16 000	22 200	2 700	14 000	21 000		NK19/20R	25	0.3	0.032
20	+0.033 +0.020	28	0.3	10 300	12 800	1 560	13 000	20 000	RNA4902R	26	0.3	0.022	
		28	0.3	13 200	17 500	2 140	13 000	20 000	NK20/16RCT	26	0.3	0.027	
		28	0.3	14 100	19 100	2 330	13 000	20 000	RNA5902CT	26	0.3	0.033	
		28	0.3	16 700	23 800	2 900	13 000	20 000	NK20/20R	26	0.3	0.034	
		28	0.3	17 600	25 300	3 100	13 000	20 000	RNA6902R	26	0.3	0.040	
21	+0.033 +0.020	29	0.3	13 700	18 700	2 280	13 000	19 000	NK21/16R	27	0.3	0.028	
		29	0.3	17 400	25 400	3 100	13 000	19 000		NK21/20R	27	0.3	0.035
22	+0.033 +0.020	30	0.3	14 200	19 900	2 430	12 000	18 000	NK22/16R	28	0.3	0.034	
		30	0.3	18 000	27 000	3 300	12 000	18 000		NK22/20R	28	0.3	0.037
		30	0.3	11 200	14 600	1 780	12 000	18 000		RNA4903R	28	0.3	0.022
		30	0.3	15 200	21 700	2 650	12 000	18 000		RNA5903	28	0.3	0.035
		30	0.3	18 200	27 200	3 300	12 000	18 000		RNA6903R	28	0.3	0.042
24	+0.033 +0.020	32	0.3	15 200	22 300	2 720	11 000	17 000	NK24/16R	30	0.3	0.032	
		32	0.3	18 600	28 800	3 500	11 000	17 000		NK24/20R	30	0.3	0.040
25	+0.033 +0.020	33	0.3	15 100	22 400	2 730	11 000	16 000	NK25/16R	31	0.3	0.033	
		33	0.3	19 200	30 500	3 700	11 000	16 000		NK25/20RCT	31	0.3	0.042
		37	0.3	21 300	25 500	3 100	11 000	16 000		RNA4904RCT	35	0.3	0.052
		37	0.3	28 400	37 000	4 500	11 000	16 000		RNA5904	35	0.3	0.084
		37	0.3	36 500	50 500	6 150	11 000	16 000		RNA6904R	35	0.3	0.100
26	+0.033 +0.020	34	0.3	15 600	23 600	2 880	10 000	15 000	8E-NK26/16RCT	32	0.3	0.034	
		34	0.3	19 100	30 500	3 700	10 000	15 000		NK26/20R	32	0.3	0.042
28	+0.033 +0.020	37	0.3	22 300	34 000	4 150	9 500	14 000	NK28/20R	35	0.3	0.052	
		37	0.3	26 700	48 000	5 850	9 500	14 000		NK28/30RCT	35	0.3	0.082

1) Smallest allowable dimension for chamfer dimension r .
2) Largest allowable dimension for fillet radius r_a of housing and shaft.

Needle Roller Bearings

Machined-ring needle roller bearings without an inner ring

RNA49 type
RNA59 type
RNA69 type
NK type

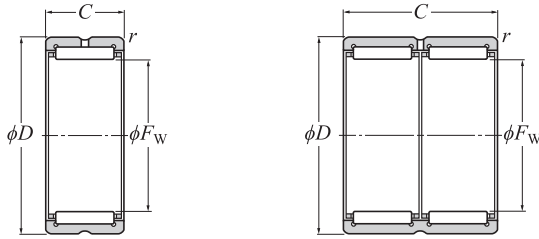

RNA49·R type, RNA59 type
RNA69·R type ($\phi F_w \leq 35$ mm)
NK·R type

RNA69 type·R type
($\phi F_w \geq 40$ mm)

F_w 28–40 mm

F_w	Boundary dimensions			Basic load rating		Fatigue load limit N	Allowable speed		Number	Installation-related dimensions		Mass kg (approx.)	
	mm			dynamic N	static C_{0r}		min^{-1}			mm			kg
	D	C	$r_s \text{ min}^{-1}$	C_r	C_{0r}		Grease lubrication	Oil lubrication		D_a Max.	r_{as}^2 Max.		
28	39	17	0.3	23 200	29 300	3 600	9 500	14 000	RNA49/22R	37	0.3	0.050	
	39	23	0.3	26 400	37 500	4 600	9 500	14 000	RNA59/22	37	0.3	0.092	
	39	30	0.3	40 000	58 500	7 150	9 500	14 000	RNA69/22R	37	0.3	0.100	
29	38	20	0.3	22 200	34 000	4 150	9 500	14 000	NK29/20R	36	0.3	0.054	
	38	30	0.3	27 500	50 500	6 150	9 500	14 000	NK29/30R	36	0.3	0.084	
30	40	20	0.3	22 100	34 000	4 150	8 500	13 000	NK30/20R	38	0.3	0.065	
	40	30	0.3	33 000	57 000	6 950	8 500	13 000	NK30/30R	38	0.3	0.098	
	42	17	0.3	24 000	31 500	3 800	8 500	13 000	RNA4905R	40	0.3	0.061	
	42	23	0.3	30 500	43 000	5 200	8 500	13 000	RNA5905	40	0.3	0.101	
	42	30	0.3	41 500	63 000	7 650	8 500	13 000	RNA6905R	40	0.3	0.112	
32	42	20	0.3	23 500	37 500	4 600	8 500	13 000	NK32/20R	40	0.3	0.068	
	42	30	0.3	34 000	60 500	7 350	8 500	13 000	NK32/30R	40	0.3	0.102	
	45	17	0.3	24 800	33 500	4 050	8 500	13 000	RNA49/28RCT	43	0.3	0.073	
	45	23	0.3	32 000	45 500	5 550	8 500	13 000	RNA59/28	43	0.3	0.108	
	45	30	0.3	43 000	67 000	8 150	8 500	13 000	RNA69/28R	43	0.3	0.135	
35	45	20	0.3	24 800	41 500	5 050	7 500	11 000	NK35/20RCT	43	0.3	0.074	
	45	30	0.3	36 000	66 500	8 100	7 500	11 000	NK35/30R	43	0.3	0.112	
	47	17	0.3	25 500	35 500	4 300	7 500	11 000	RNA4906R	45	0.3	0.069	
	47	23	0.3	32 500	48 500	5 950	7 500	11 000	RNA5906	45	0.3	0.108	
	47	30	0.3	42 500	67 500	8 250	7 500	11 000	RNA6906R	45	0.3	0.126	
37	47	20	0.3	25 300	43 500	5 300	7 500	11 000	NK37/20R	45	0.3	0.077	
	47	30	0.3	36 500	69 500	8 500	7 500	11 000	NK37/30R	45	0.3	0.107	
38	48	20	0.3	25 900	45 000	5 500	7 500	11 000	NK38/20R	46	0.3	0.079	
	48	30	0.3	37 500	73 000	8 900	7 500	11 000	NK38/30R	46	0.3	0.107	
40	50	20	0.3	26 400	47 000	5 750	6 500	10 000	NK40/20R	48	0.3	0.083	
	50	30	0.3	38 500	76 000	9 250	6 500	10 000	NK40/30R	48	0.3	0.125	
	52	20	0.6	31 500	47 500	5 800	6 500	10 000	RNA49/32R	48	0.6	0.089	
	52	27	0.6	38 000	61 000	7 450	6 500	10 000	RNA59/32	48	0.6	0.149	
	52	36	0.6	47 500	82 000	10 000	6 500	10 000	RNA69/32R	48	0.6	0.162	

1) Smallest allowable dimension for chamfer dimension r .
2) Largest allowable dimension for fillet radius r_a of housing and shaft.

Needle Roller Bearings

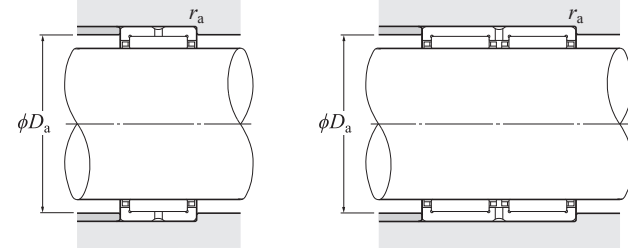

F_w 42–63 mm

F_w	Boundary dimensions			Basic load rating		Fatigue load limit N	Allowable speed		Number	Installation-related dimensions		Mass kg (approx.)	
	mm			dynamic N	static C_{0r}		min^{-1}			mm			kg
	D	C	$r_s \text{ min}^{-1}$	C_r	C_{0r}		Grease lubrication	Oil lubrication		D_a Max.	r_{as}^2 Max.		
42	52	20	0.3	26 900	49 000	5 950	6 500	9 500	NK42/20R	50	0.3	0.086	
	52	30	0.3	39 000	79 000	9 650	6 500	9 500	NK42/30R	50	0.3	0.130	
	55	20	0.6	32 000	50 000	6 100	6 500	9 500	RNA4907R	51	0.6	0.107	
	55	27	0.6	39 000	64 500	7 850	6 500	9 500	RNA5907	51	0.6	0.176	
	55	36	0.6	49 000	86 500	10 500	6 500	9 500	RNA6907R	51	0.6	0.193	
43	53	20	0.3	27 500	51 000	6 200	6 500	9 500	NK43/20R	51	0.3	0.086	
	53	30	0.3	40 000	82 000	10 000	6 500	9 500	NK43/30R	51	0.3	0.133	
45	55	20	0.3	28 000	52 500	6 450	6 000	9 000	NK45/20R	53	0.3	0.092	
	55	30	0.3	41 000	85 500	10 400	6 000	9 000	NK45/30RCT	53	0.3	0.139	
47	57	20	0.3	28 800	55 500	6 800	5 500	8 500	NK47/20RCT	55	0.3	0.095	
	57	30	0.3	42 500	91 500	11 200	5 500	8 500	NK47/30R	55	0.3	0.142	
48	62	22	0.6	43 500	66 500	8 150	5 500	8 500	RNA4908R	58	0.6	0.140	
	62	30	0.6	53 000	92 500	11 300	5 500	8 500	RNA5908	58	0.6	0.225	
	62	40	0.6	67 000	116 000	14 100	5 500	8 500	RNA6908R	58	0.6	0.256	
50	62	25	0.6	38 500	74 500	9 050	5 500	8 000	NK50/25RCT	58	0.6	0.158	
	62	35	0.6	51 000	106 000	12 900	5 500	8 000	NK50/35R	58	0.6	0.221	
52	68	22	0.6	46 000	73 000	8 950	5 000	7 500	RNA4909R	64	0.6	0.182	
	68	30	0.6	56 000	101 000	12 300	5 000	7 500	RNA5909	64	0.6	0.232	
	68	40	0.6	70 500	127 000	15 500	5 000	7 500	RNA6909R	64	0.6	0.273	
55	68	25	0.6	41 000	82 000	10 000	5 000	7 500	NK55/25R	64	0.6	0.193	
	68	35	0.6	54 000	118 000	14 300	5 000	7 500	NK55/35R	64	0.6	0.26	
58	72	22	0.6	48 000	80 000	9 750	4 700	7 000	RNA4910R	68	0.6	0.163	
	72	30	0.6	58 000	110 000	13 400	4 700	7 000	RNA5910	68	0.6	0.289	
	72	40	0.6	74 000	139 000	17 000	4 700	7 000	RNA6910R	68	0.6	0.320	
60	72	25	0.6	41 000	85 000	10 400	4 300	6 500	NK60/25R	68	0.6	0.185	
	72	35	0.6	57 000	130 000	15 800	4 300	6 500	NK60/35R	68	0.6	0.258	
63	80	25	1	58 500	99 500	12 100	4 300	6 500	RNA4911R	75	1	0.255	
	80	34	1	76 500	140 000	17 100	4 300	6 500	RNA5911	75	1	0.367	
	80	45	1	94 000	183 000	22 300	4 300	6 500	RNA6911R	75	1	0.470	

1) Smallest allowable dimension for chamfer dimension r .
2) Largest allowable dimension for fillet radius r_a of housing and shaft.

Needle Roller Bearings

Machined-ring needle roller bearings without an inner ring

RNA49 type
RNA59 type
RNA69 type
NK type

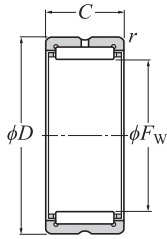

RNA48 type
RNA49··R type
RNA59 type
NK··R type

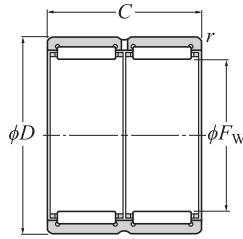

RNA69··R type

F_w 65–90 mm

F_w	Boundary dimensions			Basic load rating		Fatigue load limit N C_u	Allowable speed		Number	Installation-related dimensions		Mass kg (approx.)	
	mm			dynamic	static		min^{-1}			mm			kg
	D	C	$r_s \text{ min}^{-1}$	C_r	C_{0r}		Grease lubrication	Oil lubrication		D_a Max.	$r_{as}^{(2)}$ Max.		
65	+0.049 +0.030	78 78	25 35	0.6 0.6	45 000 60 000	98 000 142 000	12 000 17 300	4 000 4 000	6 000 6 000	NK65/25R NK65/35R	74 74	0.6 0.6	0.221 0.310
68	+0.049 +0.030	82	25	1	44 500	89 000	10 800	4 000	6 000	NK68/25R	77	0.6	0.241
		82	35	0.6	63 000	139 000	17 000	4 000	6 000	NK68/35R	78	0.6	0.338
		85	25	1	61 500	108 000	13 100	4 000	6 000	RNA4912R	80	1	0.275
		85	34	1	80 500	153 000	18 600	4 000	6 000	RNA5912	80	1	0.408
85	45	1	95 500	191 000	23 200	4 000	6 000	RNA6912R	80	1	0.488		
70	+0.049 +0.030	85	25	0.6	45 000	91 500	11 200	3 700	5 500	NK70/25R	81	0.6	0.275
		85	35	0.6	64 000	144 000	17 600	3 700	5 500	NK70/35R	81	0.6	0.386
72	+0.049 +0.030	90	25	1	62 500	112 000	13 700	3 700	5 500	RNA4913R	85	1	0.312
		90	34	1	84 000	165 000	20 100	3 700	5 500	RNA5913	85	1	0.462
		90	45	1	97 000	198 000	24 200	3 700	5 500	RNA6913R	85	1	0.520
73	+0.049 +0.030	90	25	0.6	54 000	100 000	12 200	3 700	5 500	NK73/25R	86	0.6	0.302
		90	35	0.6	76 500	156 000	19 100	3 700	5 500	NK73/35R	86	0.6	0.428
75	+0.049 +0.030	92	25	0.6	55 000	104 000	12 600	3 700	5 500	NK75/25R	88	0.6	0.315
		92	35	0.6	78 000	162 000	19 800	3 700	5 500	NK75/35R	88	0.6	0.492
80	+0.049 +0.030	95	25	1	57 000	119 000	14 500	3 300	5 000	NK80/25R	90	1	0.301
		95	35	1	79 500	184 000	22 400	3 300	5 000	NK80/35R	90	1	0.425
		100	30	1	85 500	156 000	19 000	3 300	5 000	RNA4914R	95	1	0.460
		100	40	1	103 000	187 000	22 800	3 300	5 000	RNA5914	95	1	0.706
		100	54	1	130 000	267 000	32 500	3 300	5 000	RNA6914R	95	1	0.857
85	+0.058 +0.036	105	25	1	70 500	123 000	15 000	3 100	4 700	NK85/25R	100	1	0.404
		105	30	1	87 000	162 000	19 700	3 100	4 700	RNA4915R	100	1	0.489
		105	35	1	100 000	193 000	23 600	3 100	4 700	NK85/35R	100	1	0.517
		105	40	1	109 000	205 000	25 000	3 100	4 700	RNA5915	100	1	0.745
		105	54	1	132 000	277 000	34 000	3 100	4 700	RNA6915R	100	1	0.935
90	+0.058 +0.036	110	25	1	71 500	128 000	15 600	2 900	4 400	NK90/25R	105	1	0.426
		110	30	1	90 500	174 000	21 200	2 900	4 400	RNA4916R	105	1	0.516
		110	35	1	104 000	208 000	25 400	2 900	4 400	NK90/35R	105	1	0.604

1) Smallest allowable dimension for chamfer dimension r .
2) Largest allowable dimension for fillet radius r_a of housing and shaft.

Needle Roller Bearings

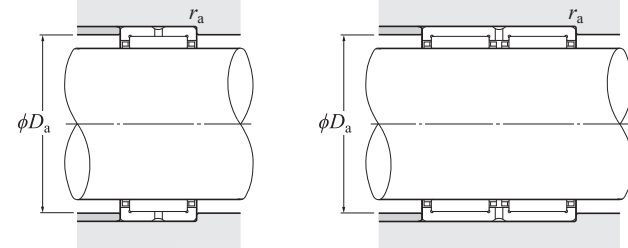

F_w 90–135 mm

F_w	Boundary dimensions			Basic load rating		Fatigue load limit N C_u	Allowable speed		Number	Installation-related dimensions		Mass kg (approx.)	
	mm			dynamic	static		min^{-1}			mm			kg
	D	C	$r_s \text{ min}^{-1}$	C_r	C_{0r}		Grease lubrication	Oil lubrication		D_a Max.	$r_{as}^{(2)}$ Max.		
90	+0.058 +0.036	110 110	40 54	1 1	115 000 138 000	223 000 298 000	27 200 36 500	2 900 2 900	4 400 4 400	RNA5916 RNA6916R	105 105	1 1	0.787 0.987
95	+0.058 +0.036	115	26	1	74 500	137 000	16 600	2 800	4 200	NK95/26R	110	1	0.364
		115	36	1	108 000	223 000	27 000	2 800	4 200	NK95/36R	110	1	0.652
100	+0.058 +0.036	120	26	1	73 500	137 000	16 500	2 700	4 000	NK100/26R	115	1	0.487
		120	35	1.1	112 000	237 000	28 400	2 700	4 000	RNA4917R	113.5	1	0.657
		120	36	1	107 000	223 000	26 700	2 700	4 000	NK100/36R	115	1	0.679
		120	46	1.1	137 000	290 000	34 500	2 700	4 000	RNA5917	113.5	1	1.00
120	63	1.1	169 000	400 000	48 000	2 700	4 000	RNA6917R	113.5	1	1.20		
105	+0.058 +0.036	125	26	1	76 500	147 000	17 300	2 500	3 800	NK105/26R	120	1	0.506
		125	35	1.1	116 000	252 000	29 800	2 500	3 800	RNA4918R	118.5	1	0.697
		125	36	1	111 000	238 000	28 100	2 500	3 800	NK105/36R	120	1	0.713
		125	46	1.1	143 000	310 000	37 000	2 500	3 800	RNA5918	118.5	1	1.04
		125	63	1.1	175 000	425 000	50 500	2 500	3 800	RNA6918R	118.5	1	1.33
110	+0.058 +0.036	130	30	1.1	97 500	204 000	23 800	2 400	3 600	NK110/30R	123.5	1	0.612
		130	35	1.1	118 000	260 000	30 500	2 400	3 600	RNA4919R	123.5	1	0.719
		130	40	1.1	129 000	292 000	34 000	2 400	3 600	NK110/40R	123.5	1	0.830
		130	46	1.1	149 000	335 000	39 000	2 400	3 600	RNA5919	123.5	1	1.13
130	63	1.1	177 000	440 000	51 000	2 400	3 600	RNA6919R	123.5	1	1.46		
115	+0.058 +0.036	140	40	1.1	127 000	260 000	29 900	2 300	3 500	RNA4920	133.5	1	1.15
		140	54	1.1	182 000	395 000	45 500	2 300	3 500	RNA5920	133.5	1	1.76
120	+0.058 +0.036	140	30	1	93 500	210 000	23 900	2 200	3 300	RNA4822	135	1	0.670
		140	40	1.1	113 000	268 000	30 500	2 200	3 300	NK120/40	133.5	1	0.910
125	+0.068 +0.043	150	40	1.1	131 000	279 000	31 500	2 100	3 200	RNA4922	143.5	1	1.24
		150	54	1.1	193 000	440 000	49 500	2 100	3 200	RNA5922	143.5	1	1.89
130	+0.068 +0.043	150	30	1	99 500	233 000	25 900	2 100	3 100	RNA4824	145	1	0.730
		150	40	1.1	116 000	283 000	31 500	2 100	3 100	NK130/40	143.5	1	0.980
135	+0.068 +0.043	165	45	1.1	180 000	380 000	41 500	2 000	3 000	RNA4924	158.5	1	1.86
		165	60	1.1	246 000	530 000	57 500	2 000	3 000	RNA5924	158.5	1	2.67

1) Smallest allowable dimension for chamfer dimension r .
2) Largest allowable dimension for fillet radius r_a of housing and shaft.

Needle Roller Bearings



Machined-ring needle roller bearings without an inner ring

RNA48 type
RNA49 type
RNA59 type
RNA69 type
NK type

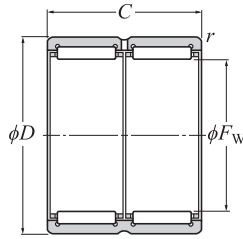
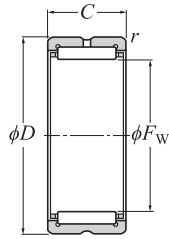

RNA48 type
RNA49·R type, RNA49 type
RNA59 type
NK·R type, NK type

F_w 145–245 mm

F_w	Boundary dimensions			Basic load rating		Fatigue load limit N C_u	Allowable speed		Number	Installation-related dimensions		Mass kg (approx.)	
	mm			dynamic	static		min^{-1}			mm			kg
	D	C	$r_s \text{ min}^{-1}$	C_r	C_{0r}		Grease lubrication	Oil lubrication		D_a Max.	$r_{as}^{2)}$ Max.		
145	+0.068 +0.043	165 170 170	35 32 42	1.1 1.5 1.5	118 000 111 000 153 000	305 000 238 000 360 000	32 500 25 600 38 500	1 900 1 900 1 900	2 800 2 800 2 800	RNA4826 NK145/32 NK145/42	158.5 162.5 162.5	1 1.5 1.5	0.95 1.12 1.49
150	+0.068 +0.043	180 180	50 67	1.5 1.5	202 000 296 000	455 000 690 000	48 000 73 000	1 800 1 800	2 700 2 700	RNA4926 RNA5926	172 172	1.5 1.5	2.21 3.21
155	+0.068 +0.043	175 180 180	35 32 42	1.1 1.5 1.5	121 000 114 000 156 000	315 000 252 000 380 000	33 500 26 500 40 000	1 700 1 700 1 700	2 600 2 600 2 600	RNA4828 NK155/32 NK155/42	168.5 172 172	1 1.5 1.5	1.02 1.20 1.59
160	+0.068 +0.043	190 190	50 67	1.5 1.5	209 000 315 000	485 000 760 000	50 500 79 000	1 700 1 700	2 500 2 500	RNA4928 RNA5928	182 182	1.5 1.5	2.35 3.48
165	+0.068 +0.043	190 190 190	32 40 42	1.5 1.1 1.5	117 000 152 000 160 000	265 000 390 000 400 000	27 400 40 500 41 000	1 600 1 600 1 600	2 400 2 400 2 400	NK165/32 RNA4830 NK165/42	182 183.5 182	1.5 1 1.5	1.42 1.60 1.66
170	+0.068 +0.043	210	60	2	261 000	610 000	62 500	1 600	2 400	RNA4930	201	2	2.98
175	+0.068 +0.043	200	40	1.1	160 000	425 000	43 500	1 500	2 300	RNA4832	193.5	1	1.70
180	+0.068 +0.043	220	60	2	270 000	650 000	65 500	1 500	2 200	RNA4932	211	2	3.10
185	+0.079 +0.050	215	45	1.1	185 000	495 000	49 500	1 500	2 200	RNA4834	208.5	1	2.54
190	+0.079 +0.050	230	60	2	279 000	690 000	68 500	1 400	2 100	RNA4934	221	2	3.22
195	+0.079 +0.050	225	45	1.1	195 000	540 000	53 500	1 400	2 100	RNA4836	218.5	1	2.68
205	+0.079 +0.050	250	69	2	375 000	890 000	86 000	1 300	2 000	RNA4936	241	2	4.48
210	+0.079 +0.050	240	50	1.5	227 000	680 000	65 500	1 300	1 900	RNA4838	232	1.5	3.21
215	+0.079 +0.050	260	69	2	390 000	945 000	90 500	1 300	1 900	RNA4938	251	2	4.53
220	+0.079 +0.050	250	50	1.5	231 000	705 000	67 000	1 200	1 800	RNA4840	242	1.5	3.35
225	+0.079 +0.050	280	80	2.1	505 000	1 180 000	111 000	1 200	1 800	RNA4940	269	2	7.20
240	+0.079 +0.050	270	50	1.5	244 000	780 000	72 500	1 100	1 700	RNA4844	262	1.5	3.62
245	+0.079 +0.050	300	80	2.1	525 000	1 270 000	116 000	1 100	1 600	RNA4944	289	2	7.81

1) Smallest allowable dimension for chamfer dimension r .
2) Largest allowable dimension for fillet radius r_a of housing and shaft.

Needle Roller Bearings

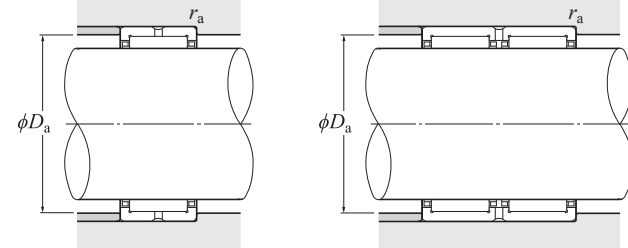

F_w 265–490 mm

F_w	Boundary dimensions			Basic load rating		Fatigue load limit N C_u	Allowable speed		Number	Installation-related dimensions		Mass kg (approx.)	
	mm			dynamic	static		min^{-1}			mm			kg
	D	C	$r_s \text{ min}^{-1}$	C_r	C_{0r}		Grease lubrication	Oil lubrication		D_a Max.	$r_{as}^{2)}$ Max.		
265	+0.088 +0.056	300 320	60 80	2 2.1	365 000 540 000	1 090 000 1 350 000	98 500 121 000	1 000 1 000	1 500 1 500	RNA4848 RNA4948	291 309	2 2	5.40 8.40
285	+0.088 +0.056	320	60	2	375 000	1 170 000	103 000	950	1 400	RNA4852	311	2	5.80
290	+0.088 +0.056	360	100	2.1	810 000	1 920 000	166 000	950	1 400	RNA4952	349	2	15.9
305	+0.088 +0.056	350	69	2	455 000	1 300 000	112 000	850	1 300	RNA4856	341	2	9.30
310	+0.088 +0.056	380	100	2.1	840 000	2 050 000	175 000	850	1 300	RNA4956	369	2	16.7
330	+0.098 +0.062	380	80	2.1	625 000	1 770 000	149 000	800	1 200	RNA4860	369	2	12.7
340	+0.098 +0.062	420	118	3	1 080 000	2 640 000	219 000	800	1 200	RNA4960	407	2.5	24.0
350	+0.098 +0.062	400	80	2.1	640 000	1 850 000	153 000	750	1 100	RNA4864	389	2	13.4
360	+0.098 +0.062	440	118	3	1 120 000	2 820 000	230 000	750	1 100	RNA4964	427	2.5	25.2
370	+0.098 +0.062	420	80	2.1	655 000	1 940 000	158 000	750	1 100	RNA4868	409	2	14.0
380	+0.098 +0.062	460	118	3	1 160 000	3 000 000	242 000	750	1 100	RNA4968	447	2.5	26.5
390	+0.098 +0.062	440	80	2.1	665 000	2 020 000	162 000	650	1 000	RNA4872	429	2	14.8
400	+0.108 +0.068	480	118	3	1 200 000	3 200 000	253 000	650	1 000	RNA4972	467	2.5	28.2
415	+0.108 +0.068	480	100	2.1	1 000 000	2 840 000	223 000	650	950	RNA4876	469	2	26.0
430	+0.108 +0.068	520	140	4	1 400 000	3 750 000	292 000	650	950	RNA4976	504	3	38.6
450	+0.108 +0.068	540	140	4	1 450 000	4 000 000	306 000	600	900	RNA4980	524	3	40.1
470	+0.108 +0.068	560	140	4	1 500 000	4 250 000	320 000	550	850	RNA4984	544	3	51.6
490	+0.108 +0.068	600	160	4	1 750 000	4 600 000	342 000	550	800	RNA4988	584	3	66.9

1) Smallest allowable dimension for chamfer dimension r .
2) Largest allowable dimension for fillet radius r_a of housing and shaft.

Needle Roller Bearings



Machined-ring needle roller bearings with an inner ring

NA49 type
NA59 type
NA69 type
NK+IR type

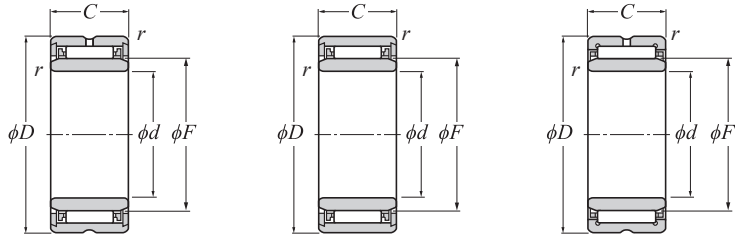

NA49 type ($\phi d \leq 9$ mm) NK+IR type ($\phi d \leq 9$ mm) NA49+R type ($\phi d \geq 10$ mm)
NA59 type
NA69+R type
NK+IR type ($\phi d \geq 10$ mm)

d 5-17 mm

Boundary dimensions	Basic load rating					Fatigue load limit	Allowable speed		Number		
	mm						N	min ⁻¹			
d	D	C	r _{s min} ¹⁾	F	s ²⁾	C _r		C _{0r}	C _u	Grease lubrication	Oil lubrication
5	13	10	0.15	7	—	2 670	2 350	287	23 000	34 000	NA495T2
	15	12	0.3	8	1.5	4 000	4 100	500	21 000	32 000	NK8/12T2+IR5×8×12
	15	16	0.3	8	2	4 850	5 200	635	21 000	32 000	NK8/16T2+IR5×8×16
6	15	10	0.15	8	—	3 150	3 000	365	21 000	32 000	NA496T2T
	16	12	0.3	9	1.5	4 550	5 000	615	20 000	30 000	NK9/12T2+IR6×9×12
	16	16	0.3	9	2	5 500	6 400	780	20 000	30 000	NK9/16T2+IR6×9×16
7	17	10	0.15	9	—	3 600	3 650	445	20 000	30 000	NA497
	17	12	0.3	10	1.5	4 550	5 100	620	19 000	28 000	NK10/12T2+IR7×10×12
	17	16	0.3	10	2	5 450	6 450	790	19 000	28 000	8E-NK10/16CT+IR7×10×16
8	19	11	0.15	10	—	5 250	5 150	630	19 000	28 000	NA498CT
9	19	12	0.3	12	1.5	5 000	6 100	740	17 000	26 000	NK12/12+IR9×12×12
	19	16	0.3	12	2	6 000	7 700	940	17 000	26 000	NK12/16+IR9×12×16
	20	11	0.3	12	—	4 850	4 900	595	17 000	26 000	NA499
10	22	13	0.3	14	0.5	8 600	9 200	1 120	16 000	24 000	NA4900R
	22	16	0.3	14	0.5	10 300	11 500	1 400	16 000	24 000	NK14/16RCT+IR10×14×16
	22	20	0.3	14	0.5	13 000	15 600	1 900	16 000	24 000	NK14/20R+IR10×14×20
12	24	13	0.3	16	0.5	9 550	10 900	1 330	15 000	23 000	NA4901R
	24	16	0.3	16	0.5	12 200	14 900	1 820	15 000	23 000	NK16/16R+IR12×16×16
	24	20	0.3	16	0.5	14 600	18 800	2 290	15 000	23 000	NK16/20R+IR12×16×20
	24	22	0.3	16	1	15 400	20 000	2 440	15 000	23 000	NA6901R
15	27	16	0.3	19	0.5	13 300	17 400	2 120	14 000	21 000	NK19/16R+IR15×19×16
	27	20	0.3	19	0.5	16 000	22 200	2 700	14 000	21 000	NK19/20R+IR15×19×20
	28	13	0.3	20	0.5	10 300	12 800	1 560	13 000	20 000	NA4902R
	28	18	0.3	20	0.5	14 100	19 100	2 330	13 000	20 000	NA5902CT
	28	23	0.3	20	1	17 600	25 300	3 100	13 000	20 000	NA6902R
17	29	16	0.3	21	0.5	13 700	18 700	2 280	13 000	19 000	NK21/16R+IR17×21×16
	29	20	0.3	21	0.5	17 400	25 400	3 100	13 000	19 000	NK21/20R+IR17×21×20
	30	13	0.3	22	0.5	11 200	14 600	1 780	12 000	18 000	NA4903R

1) Smallest allowable dimension for chamfer dimension r.
2) Allowable axial movement amount of the inner ring with respect to the outer ring.
3) Largest allowable dimension for fillet radius r_{as} of housing and shaft.

Needle Roller Bearings

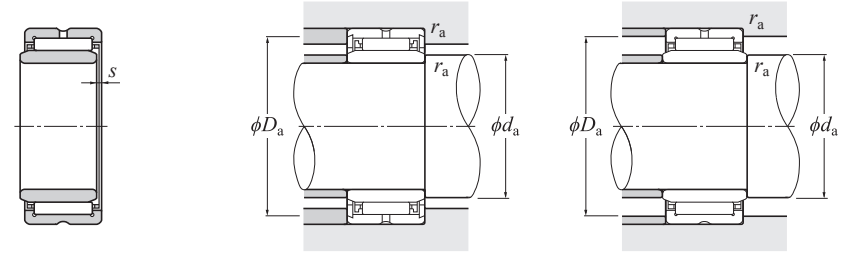

Installation-related dimensions	Mass		
	d _a Min.	D _a Max.	r _{as} ³⁾ Max.
6.2	8.5	0.15	0.007
7	9.5	0.3	0.012
7	9.5	0.3	0.016
8	9.5	0.15	0.009
8	10.5	0.3	0.013
8	10.5	0.3	0.017
9	10.5	0.15	0.010
9	11.5	0.3	0.014
9	11.5	0.3	0.018
10	12	0.15	0.016
11	13.5	0.3	0.018
11	13.5	0.3	0.022
11	14	0.3	0.017
12	20	0.3	0.024
12	20	0.3	0.030
12	20	0.3	0.038
14	22	0.3	0.026
14	22	0.3	0.033
14	22	0.3	0.042
14	22	0.3	0.046
17	25	0.3	0.039
17	25	0.3	0.045
17	26	0.3	0.036
17	26	0.3	0.052
17	26	0.3	0.064
19	27	0.3	0.042
19	27	0.3	0.053
19	28	0.3	0.037

Note: The number of inner rings (IR) is composed of the IR bore diameter dimension × outside diameter dimension × width dimension.

Needle Roller Bearings



Machined-ring needle roller bearings with an inner ring

NA49 type
NA59 type
NA69 type
NK+IR type

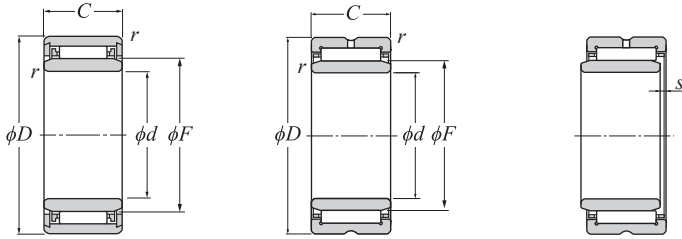

NA49·R type
NA59 type
NA69·R type
NK·R + IR type

d 17-32 mm

d	Boundary dimensions					Basic load rating		Fatigue load limit N C _u	Allowable speed		Number
	d	D	C	r _{s min} ¹⁾	F s ²⁾	dynamic N C _r	static N C _{0r}		min ⁻¹	Oil lubrication	
17	30	18	0.3	22	0.5	15 200	21 700	2 650	12 000	18 000	NA5903
	30	23	0.3	22	1	18 200	27 200	3 300	12 000	18 000	NA6903R
20	32	16	0.3	24	0.5	15 200	22 300	2 720	11 000	17 000	NK24/16R+IR20×24×16
	32	20	0.3	24	0.5	18 600	28 800	3 500	11 000	17 000	NK24/20R+IR20×24×20
	37	17	0.3	25	0.8	21 300	25 500	3 100	11 000	16 000	NA4904RCT
	37	23	0.3	25	0.8	28 400	37 000	4 500	11 000	16 000	NA5904
22	37	30	0.3	25	1	36 500	50 500	6 150	11 000	16 000	NA6904R
	34	16	0.3	26	0.5	15 600	23 600	2 880	10 000	15 000	8E-NK26/16RCT+IR22×26×16
	34	20	0.3	26	0.5	19 100	30 500	3 700	10 000	15 000	NK26/20R+IR22×26×20
	39	17	0.3	28	0.8	23 200	29 300	3 600	9 500	14 000	NA49/22R
25	39	23	0.3	28	0.8	26 400	37 500	4 600	9 500	14 000	NA59/22
	39	30	0.3	28	0.5	40 000	58 500	7 150	9 500	14 000	NA69/22R
28	38	20	0.3	29	1	22 200	34 000	4 150	9 500	14 000	NK29/20R+IR25×29×20
	38	30	0.3	29	1.5	27 500	50 500	6 150	9 500	14 000	NK29/30R+IR25×29×30
	42	17	0.3	30	0.8	24 000	31 500	3 800	8 500	13 000	NA4905R
	42	23	0.3	30	0.8	30 500	43 000	5 200	8 500	13 000	NA5905
30	42	30	0.3	30	1	41 500	63 000	7 650	8 500	13 000	NA6905R
	42	20	0.3	32	1	23 500	37 500	4 600	8 500	13 000	NK32/20R+IR28×32×20
	42	30	0.3	32	1.5	34 000	60 500	7 350	8 500	13 000	NK32/30R+IR28×32×30
	45	17	0.3	32	0.8	24 800	33 500	4 050	8 500	13 000	NA49/28RCT
32	45	23	0.3	32	0.8	32 000	45 500	5 550	8 500	13 000	NA59/28
	45	30	0.3	32	1	43 000	67 000	8 150	8 500	13 000	NA69/28R
	45	20	0.3	35	0.5	24 800	41 500	5 050	7 500	11 000	NK35/20RCT+IR30×35×20
	45	30	0.3	35	1	36 000	66 500	8 100	7 500	11 000	NK35/30R+IR30×35×30
32	47	17	0.3	35	0.8	25 500	35 500	4 300	7 500	11 000	NA4906R
	47	23	0.3	35	0.8	32 500	48 500	5 950	7 500	11 000	NA5906
	47	30	0.3	35	1	42 500	67 500	8 250	7 500	11 000	NA6906R
	47	20	0.3	37	0.5	25 300	43 500	5 300	7 500	11 000	NK37/20R+IR32×37×20
32	47	30	0.3	37	1	36 500	69 500	8 500	7 500	11 000	NK37/30R+IR32×37×30
	52	20	0.6	40	0.8	31 500	47 500	5 800	6 500	10 000	NA49/32R

1) Smallest allowable dimension for chamfer dimension r.
2) Allowable axial movement amount of the inner ring with respect to the outer ring.
3) Largest allowable dimension for fillet radius r_a of housing and shaft.

Needle Roller Bearings

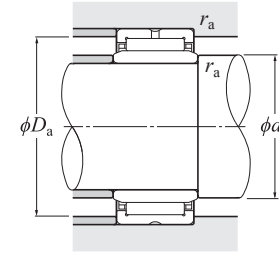

d _a	Installation-related dimensions			Mass kg (approx.)
	mm	mm	mm	
19	28	0.3	0.056	
19	28	0.3	0.069	
22	30	0.3	0.049	
22	30	0.3	0.061	
22	35	0.3	0.074	
22	35	0.3	0.115	
22	35	0.3	0.141	
24	32	0.3	0.046	
24	32	0.3	0.064	
24	37	0.3	0.080	
24	37	0.3	0.134	
24	37	0.3	0.154	
27	36	0.3	0.079	
27	36	0.3	0.123	
27	40	0.3	0.088	
27	40	0.3	0.139	
27	40	0.3	0.162	
30	40	0.3	0.096	
30	40	0.3	0.146	
30	43	0.3	0.098	
30	43	0.3	0.142	
30	43	0.3	0.179	
32	43	0.3	0.112	
32	43	0.3	0.171	
32	45	0.3	0.101	
32	45	0.3	0.152	
32	45	0.3	0.185	
34	45	0.3	0.117	
34	45	0.3	0.170	
36	48	0.6	0.157	

Note: The number of inner rings (IR) is composed of the IR bore diameter dimension × outside diameter dimension × width dimension.

Needle Roller Bearings



Machined-ring needle roller bearings with an inner ring

NA49 type
NA59 type
NA69 type
NK+IR type

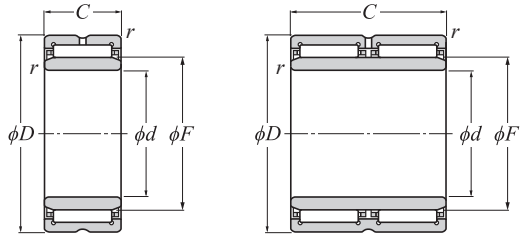

NA49··R type
NA59 type
NK··R + IR type

NA69··R type

d 32–55 mm

d	Boundary dimensions					Basic load rating		Fatigue load limit N C _u	Allowable speed		Number
	D	C	r _{s min} ¹⁾	F	s ²⁾	dynamic N C _r	static N C _{0r}		min ⁻¹ Grease lubrication	Oil lubrication	
32	52	27	0.6	40	0.8	38 000	61 000	7 450	6 500	10 000	NA59/32
	52	36	0.6	40	0.5	47 500	82 000	10 000	6 500	10 000	NA69/32R
35	50	20	0.3	40	0.5	26 400	47 000	5 750	6 500	10 000	NK40/20R+IR35×40×20
	50	30	0.3	40	1	38 500	76 000	9 250	6 500	10 000	NK40/30R+IR35×40×30
	55	20	0.6	42	0.8	32 000	50 000	6 100	6 500	9 500	NA4907R
	55	27	0.6	42	0.8	39 000	64 500	7 850	6 500	9 500	NA5907
	55	36	0.6	42	0.5	49 000	86 500	10 500	6 500	9 500	NA6907R
38	53	20	0.3	43	0.5	27 500	51 000	6 200	6 500	9 500	NK43/20R+IR38×43×20
	53	30	0.3	43	1	40 000	82 000	10 000	6 500	9 500	NK43/30R+IR38×43×30
40	55	20	0.3	45	0.5	28 000	52 500	6 450	6 000	9 000	NK45/20R+IR40×45×20
	55	30	0.3	45	1	41 000	85 500	10 400	6 000	9 000	NK45/30RCT+IR40×45×30
	62	22	0.6	48	1	43 500	66 500	8 150	5 500	8 500	NA4908R
	62	30	0.6	48	1	53 000	92 500	11 300	5 500	8 500	NA5908
	62	40	0.6	48	0.5	67 000	116 000	14 100	5 500	8 500	NA6908R
42	57	20	0.3	47	0.5	28 800	55 500	6 800	5 500	8 500	NK47/20RCT+IR42×47×20
	57	30	0.3	47	1	42 500	91 500	11 200	5 500	8 500	NK47/30R+IR42×47×30
45	62	25	0.6	50	1.5	38 500	74 500	9 050	5 500	8 000	NK50/25RCT+IR45×50×25
	62	35	0.6	50	2	51 000	106 000	12 900	5 500	8 000	NK50/35R+IR45×50×35
	68	22	0.6	52	1	46 000	73 000	8 950	5 000	7 500	NA4909R
	68	30	0.6	52	1	56 000	101 000	12 300	5 000	7 500	NA5909
	68	40	0.6	52	0.5	70 500	127 000	15 500	5 000	7 500	NA6909R
50	68	25	0.6	55	1.5	41 000	82 000	10 000	5 000	7 500	NK55/25R+IR50×55×25
	68	35	0.6	55	2	54 000	118 000	14 300	5 000	7 500	NK55/35R+IR50×55×35
	72	22	0.6	58	1	48 000	80 000	9 750	4 700	7 000	NA4910R
	72	30	0.6	58	1	58 000	110 000	13 400	4 700	7 000	NA5910
	72	40	0.6	58	0.5	74 000	139 000	17 000	4 700	7 000	NA6910R
55	72	25	0.6	60	1.5	41 000	85 000	10 400	4 300	6 500	NK60/25R+IR55×60×25
	72	35	0.6	60	2	57 000	130 000	15 800	4 300	6 500	NK60/35R+IR55×60×35
	80	25	1	63	1.5	58 500	99 500	12 100	4 300	6 500	NA4911R

1) Smallest allowable dimension for chamfer dimension r.
2) Allowable axial movement amount of the inner ring with respect to the outer ring.
3) Largest allowable dimension for fillet radius r_a of housing and shaft.

Needle Roller Bearings

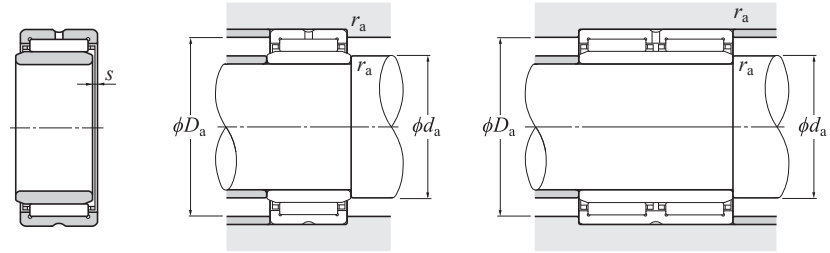

d _a	Installation-related dimensions			Mass kg (approx.)
	mm D _a Min.	mm D _a Max.	mm r _{as} ³⁾ Max.	
36	48	0.6	0.241	
36	48	0.6	0.286	
37	48	0.3	0.130	
37	48	0.3	0.193	
39	51	0.6	0.171	
39	51	0.6	0.256	
39	51	0.6	0.310	
40	51	0.3	0.134	
40	51	0.3	0.207	
42	53	0.3	0.143	
42	53	0.3	0.216	
44	58	0.6	0.232	
44	58	0.6	0.348	
44	58	0.6	0.426	
44	55	0.3	0.148	
44	55	0.3	0.222	
48	58	0.6	0.229	
48	58	0.6	0.322	
49	64	0.6	0.270	
49	64	0.6	0.396	
49	64	0.6	0.437	
53	64	0.6	0.271	
53	64	0.6	0.379	
54	68	0.6	0.276	
54	68	0.6	0.498	
54	68	0.6	0.529	
58	68	0.6	0.271	
58	68	0.6	0.379	
60	75	1	0.396	

Note: The number of inner rings (IR) is composed of the IR bore diameter dimension × outside diameter dimension × width dimension.

Needle Roller Bearings



Machined-ring needle roller bearings with an inner ring

NA49 type
NA59 type
NA69 type
NK+IR type

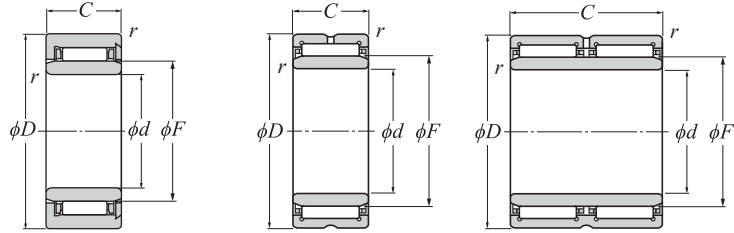

NA49··R type
NA59 type
NK··R + IR type

NA69··R type

d 55-85 mm

	Boundary dimensions					Basic load rating		Fatigue load limit N C _u	Allowable speed		Number
	mm					dynamic	static		min ⁻¹		
	d	D	C	r _{s min} ¹⁾	F s ²⁾	C _r	C _{0r}	N	Grease lubrication	Oil lubrication	
55	80	34	1	63	1.5	76 500	140 000	17 100	4 300	6 500	NA5911
	80	45	1	63	1.5	94 000	183 000	22 300	4 300	6 500	NA6911R
60	82	25	1	68	1	44 500	89 000	10 800	4 000	6 000	NK68/25R+IR60×68×25
	82	35	0.6	68	1	63 000	139 000	17 000	4 000	6 000	NK68/35R+IR60×68×35
	85	25	1	68	1.5	61 500	108 000	13 100	4 000	6 000	NA4912R
	85	34	1	68	1.5	80 500	153 000	18 600	4 000	6 000	NA5912
	85	45	1	68	1.5	95 500	191 000	23 200	4 000	6 000	NA6912R
65	90	25	0.6	73	1	54 000	100 000	12 200	3 700	5 500	NK73/25R+IR65×73×25
	90	25	1	72	1.5	62 500	112 000	13 700	3 700	5 500	NA4913R
	90	34	1	72	1.5	84 000	165 000	20 100	3 700	5 500	NA5913
	90	35	0.6	73	1	76 500	156 000	19 100	3 700	5 500	NK73/35R+IR65×73×35
	90	45	1	72	1.5	97 000	198 000	24 200	3 700	5 500	NA6913R
70	95	25	1	80	0.8	57 000	119 000	14 500	3 300	5 000	NK80/25R+IR70×80×25
	95	35	1	80	0.8	79 500	184 000	22 400	3 300	5 000	NK80/35R+IR70×80×35
	100	30	1	80	1.5	85 500	156 000	19 000	3 300	5 000	NA4914R
	100	40	1	80	1.5	103 000	187 000	22 800	3 300	5 000	NA5914
	100	54	1	80	1	130 000	267 000	32 500	3 300	5 000	NA6914R
75	105	25	1	85	1	70 500	123 000	15 000	3 100	4 700	NK85/25R+IR75×85×25
	105	30	1	85	1.5	87 000	162 000	19 700	3 100	4 700	NA4915R
	105	35	1	85	1	100 000	193 000	23 600	3 100	4 700	NK85/35R+IR75×85×35
	105	40	1	85	1.5	109 000	205 000	25 000	3 100	4 700	NA5915
	105	54	1	85	1	132 000	277 000	34 000	3 100	4 700	NA6915R
80	110	25	1	90	1	71 500	128 000	15 600	2 900	4 400	NK90/25R+IR80×90×25
	110	30	1	90	1.5	90 500	174 000	21 200	2 900	4 400	NA4916R
	110	35	1	90	1	104 000	208 000	25 400	2 900	4 400	NK90/35R+IR80×90×35
	110	40	1	90	1.5	115 000	223 000	27 200	2 900	4 400	NA5916
	110	54	1	90	1.5	138 000	298 000	36 500	2 900	4 400	NA6916R
85	115	26	1	95	1.5	74 500	137 000	16 600	2 800	4 200	NK95/26R+IR85×95×26
	115	36	1	95	1.5	108 000	223 000	27 000	2 800	4 200	NK95/36R+IR85×95×36

1) Smallest allowable dimension for chamfer dimension r.
2) Allowable axial movement amount of the inner ring with respect to the outer ring.
3) Largest allowable dimension for fillet radius r_a of housing and shaft.

Needle Roller Bearings

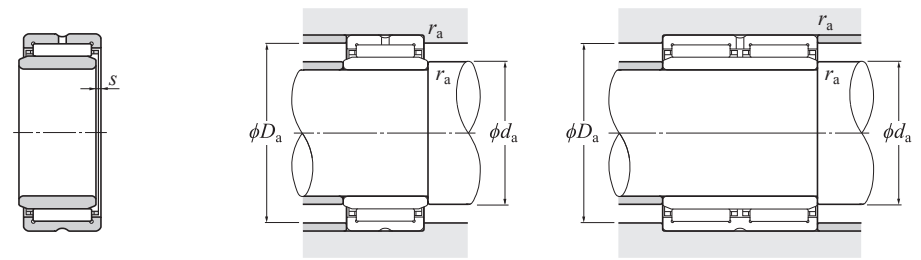

	Installation-related dimensions			Mass kg (approx.)
	d _a Min.	D _a Max.	r _{as} ³⁾ Max.	
60	75	1	0.559	
60	75	1	0.726	
65	77	0.6	0.393	
64	78	0.6	0.551	
65	80	1	0.427	
65	80	1	0.614	
65	80	1	0.758	
69	86	0.6	0.466	
70	85	1	0.454	
70	85	1	0.655	
69	86	0.6	0.660	
70	85	1	0.779	
75	90	1	0.525	
75	90	1	0.738	
75	95	1	0.727	
75	95	1	1.06	
75	95	1	1.34	
80	100	1	0.642	
80	100	1	0.776	
80	100	1	0.853	
80	100	1	1.13	
80	100	1	1.45	
85	105	1	0.680	
85	105	1	0.820	
85	105	1	0.959	
85	105	1	1.15	
85	105	1	1.53	
90	110	1	0.644	
90	110	1	1.05	

Note: The number of inner rings (IR) is composed of the IR bore diameter dimension × outside diameter dimension × width dimension.

Needle Roller Bearings

Machined-ring needle roller bearings with an inner ring

NA48 type
NA49 type
NA59 type
NA69 type
NK+IR type

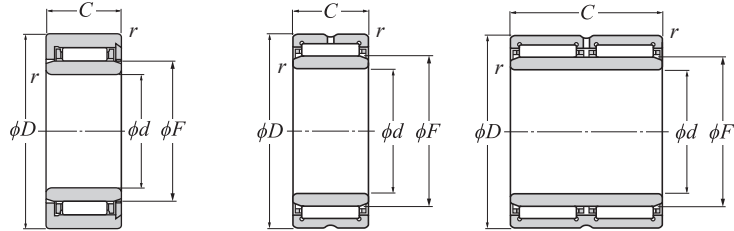

NA49··R type
NA59 type
NK··R + IR type

NA69··R type

d 85–130 mm

d	Boundary dimensions					Basic load rating		Fatigue load limit N C _u	Allowable speed		Number
	mm					dynamic C _r	static C _{0r}		min ⁻¹		
	D	C	r _{s min} ¹⁾	F	s ²⁾				Grease lubrication	Oil lubrication	
85	120	35	1.1	100	1	112 000	237 000	28 400	2 700	4 000	NA4917R
	120	46	1.1	100	1.5	137 000	290 000	34 500	2 700	4 000	NA5917
	120	63	1.1	100	1	169 000	400 000	48 000	2 700	4 000	NA6917R
90	120	26	1	100	1.5	73 500	137 000	16 400	2 700	4 000	NK100/26R+IR90×100×26
	120	36	1	100	1.5	107 000	223 000	26 700	2 700	4 000	NK100/36R+IR90×100×36
	125	35	1.1	105	1	116 000	252 000	29 800	2 500	3 800	NA4918R
	125	46	1.1	105	1	143 000	310 000	37 000	2 500	3 800	NA5918
	125	63	1.1	105	1	175 000	425 000	50 500	2 500	3 800	NA6918R
95	125	26	1	105	1.5	76 500	147 000	17 300	2 500	3 800	NK105/26R+IR95×105×26
	125	36	1	105	1.5	111 000	238 000	28 100	2 500	3 800	NK105/36R+IR95×105×36
	130	35	1.1	110	1	118 000	260 000	30 500	2 400	3 600	NA4919R
	130	46	1.1	110	1	149 000	335 000	39 000	2 400	3 600	NA5919
	130	63	1.1	110	1	177 000	440 000	51 000	2 400	3 600	NA6919R
100	130	30	1.1	110	1.5	97 500	204 000	23 800	2 400	3 600	NK110/30R+IR100×110×30
	130	40	1.1	110	2	129 000	292 000	34 000	2 400	3 600	NK110/40R+IR100×110×40
	140	40	1.1	115	2	127 000	260 000	29 900	2 300	3 500	NA4920
	140	54	1.1	115	2	182 000	395 000	45 500	2 300	3 500	NA5920
110	140	30	1	120	0.8	95 000	214 000	24 400	2 200	3 300	NA4822
	140	40	1.1	120	—	114 000	271 000	31 000	2 200	3 300	NK120/40+IR110×120×40
	150	40	1.1	125	2	131 000	279 000	31 500	2 100	3 200	NA4922
	150	54	1.1	125	2	193 000	440 000	49 500	2 100	3 200	NA5922
120	150	30	1	130	0.8	101 000	237 000	26 400	2 100	3 100	NA4824
	150	40	1.1	130	—	117 000	287 000	32 000	2 100	3 100	NK130/40+IR120×130×40
	165	45	1.1	135	2	180 000	380 000	41 500	2 000	3 000	NA4924
	165	60	1.1	135	2	246 000	530 000	57 500	2 000	3 000	NA5924
130	165	35	1.1	145	1	120 000	310 000	33 000	1 900	2 800	NA4826
	170	32	1.5	145	—	111 000	238 000	25 600	1 900	2 800	NK145/32+IR130×145×32
	170	42	1.5	145	—	153 000	360 000	38 500	1 900	2 800	NK145/42+IR130×145×42
	180	50	1.5	150	1.5	202 000	455 000	48 000	1 800	2 700	NA4926
	180	67	1.5	150	1.5	296 000	690 000	73 000	1 800	2 700	NA5926

1) Smallest allowable dimension for chamfer dimension r.
2) Allowable axial movement amount of the inner ring with respect to the outer ring.
3) Largest allowable dimension for fillet radius r_a of housing and shaft.

Needle Roller Bearings

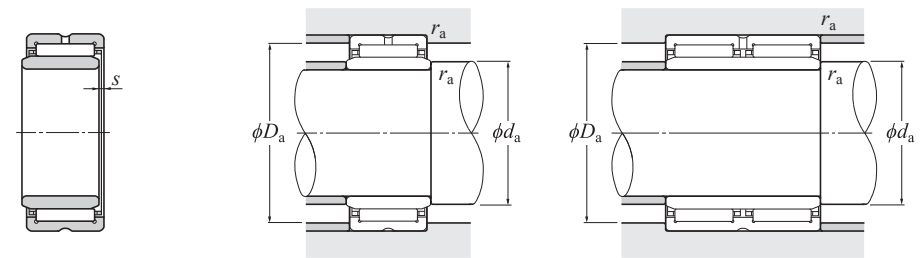

d _a	Installation-related dimensions			Mass kg (approx.)
	mm			
	Min.	Max.	r _{as} ³⁾ Max.	
91.5	113.5	1	1.24	
91.5	113.5	1	1.76	
91.5	104	1.1	2.25	
95	115	1	0.781	
95	115	1	1.09	
96.5	118.5	1	1.84	
96.5	118.5	1	2.44	
96.5	109	1.1	2.37	
100	120	1	0.819	
100	120	1	1.15	
101.5	123.5	1	1.36	
101.5	123.5	1	1.98	
101.5	123.5	1	2.63	
106.5	123.5	1	0.990	
106.5	123.5	1	1.34	
106.5	133.5	1	1.93	
106.5	133.5	1	2.85	
115	135	1	1.11	
116.5	133.5	1	1.49	
116.5	143.5	1	2.08	
116.5	143.5	1	2.98	
125	145	1	1.17	
126.5	143.5	1	1.57	
126.5	158.5	1	2.84	
126.5	158.5	1	3.92	
136.5	158.5	1	1.60	
138	162.5	1.5	1.90	
138	162.5	1.5	2.54	
138	172	1.5	3.90	
138	172	1.5	5.60	

Note: The number of inner rings (IR) is composed of the IR bore diameter dimension × outside diameter dimension × width dimension.

Needle Roller Bearings



Machined-ring needle roller bearings with an inner ring

- NA48 type
- NA49 type
- NA59 type
- NA69 type
- NK+IR type

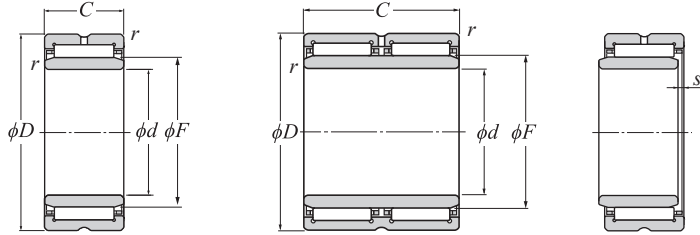

NA48 type
 NA49·R type, NA49 type
 NA59 type
 NK·R + IR type, NK + IR type
 NKS + IR type ($\phi d \geq 100$ mm)

NA69·R type

d 140–280 mm

d	Boundary dimensions					Basic load rating		Fatigue load limit N C _u	Allowable speed		Number
	D	C	r _{s min} ¹⁾	F	s ²⁾	dynamic N C _r	static N C _{0r}		min ⁻¹		
140	175	35	1.1	155	1	121 000	315 000	33 500	1 700	2 600	NA4828
	180	32	1.5	155	—	114 000	252 000	26 500	1 700	2 600	NK155/32+IR140×155×32
	180	42	1.5	155	—	156 000	380 000	40 000	1 700	2 600	NK155/42+IR140×155×42
	190	50	1.5	160	1.5	209 000	485 000	50 500	1 700	2 500	NA4928
	190	67	1.5	160	1.5	315 000	760 000	79 000	1 700	2 500	NA5928
150	190	32	1.5	165	—	117 000	265 000	27 500	1 600	2 400	NK165/32+IR150×165×32
	190	40	1.1	165	1.5	152 000	390 000	40 500	1 600	2 400	NA4830
	190	42	1.5	165	—	160 000	400 000	41 000	1 600	2 400	NK165/42+IR150×165×42
	210	60	2	170	1.5	261 000	610 000	62 500	1 600	2 400	NA4930
160	200	40	1.1	175	1.5	160 000	425 000	43 500	1 500	2 300	NA4832
	220	60	2	180	1.5	270 000	650 000	65 500	1 500	2 200	NA4932
170	215	45	1.1	185	1.5	185 000	495 000	49 500	1 500	2 200	NA4834
	230	60	2	190	1.5	279 000	690 000	68 500	1 400	2 100	NA4934
180	225	45	1.1	195	1.5	195 000	540 000	53 500	1 400	2 100	NA4836
	250	69	2	205	1.5	375 000	890 000	86 000	1 300	2 000	NA4936
190	240	50	1.5	210	1.5	227 000	680 000	65 500	1 300	1 900	NA4838
	260	69	2	215	1.5	390 000	945 000	90 500	1 300	1 900	NA4938
200	250	50	1.5	220	1.5	231 000	705 000	67 000	1 200	1 800	NA4840
	280	80	2.1	225	1.5	505 000	1 180 000	111 000	1 200	1 800	NA4940
220	270	50	1.5	240	1.5	244 000	780 000	72 500	1 100	1 700	NA4844
	300	80	2.1	245	1.5	525 000	1 270 000	116 000	1 100	1 600	NA4944
240	300	60	2	265	2	365 000	1 090 000	98 500	1 000	1 500	NA4848
	320	80	2.1	265	2	540 000	1 350 000	121 000	1 000	1 500	NA4948
260	320	60	2	285	2	375 000	1 170 000	103 000	950	1 400	NA4852
	360	100	2.1	290	2	810 000	1 920 000	166 000	950	1 400	NA4952
280	350	69	2	305	2.5	455 000	1 300 000	112 000	850	1 300	NA4856
	380	100	2.1	310	2.5	840 000	2 050 000	175 000	850	1 300	NA4956

1) Smallest allowable dimension for chamfer dimension r.
 2) Allowable axial movement amount of the inner ring with respect to the outer ring.
 3) Largest allowable dimension for fillet radius r_a of housing and shaft.

Needle Roller Bearings

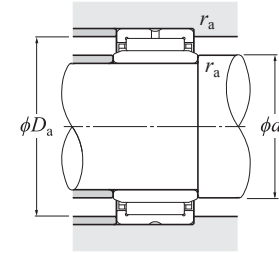

Installation-related dimensions			Mass kg (approx.)
d _a Min.	D _a Max.	r _{as} ³⁾ Max.	
146.5	168.5	1	1.82
148	172	1.5	2.04
148	172	1.5	2.69
148	182	1.5	4.05
148	182	1.5	6.18
158	182	1.5	2.32
156.5	183.5	1	2.72
158	182	1.5	2.84
159	201	2	5.33
166.5	193.5	1	2.90
169	211	2	5.60
176.5	208.5	1	3.99
179	221	2	5.87
186.5	218.5	1	4.19
189	241	2	8.58
198	232	1.5	5.62
199	251	2	8.68
208	242	1.5	5.84
211	269	2	12.2
228	262	1.5	6.37
231	289	2	13.5
249	291	2	10.0
251	309	2	14.7
269	311	2	10.8
271	349	2	25.9
289	341	2	15.5
291	369	2	27.5

Note: The number of inner rings (IR) is composed of the IR bore diameter dimension × outside diameter dimension × width dimension.

Needle Roller Bearings

NTN

Machined-ring needle roller bearings with an inner ring

NA48 type
NA49 type
NA59 type
NK+IR type

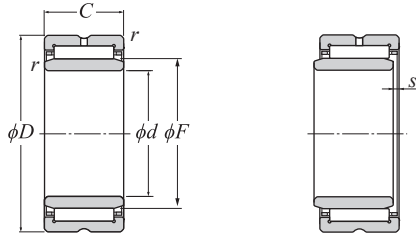

d 300–440 mm

d	Boundary dimensions					Basic load rating		Fatigue load limit N C _u	Allowable speed		Number
	D	C	r _{s min} ¹⁾	F	s ²⁾	dynamic N C _r	static N C _{0r}		min ⁻¹ Grease lubrication	Oil lubrication	
300	380	80	2.1	330	2	625 000	1 770 000	149 000	800	1 200	NA4860
	420	118	3	340	2	1 080 000	2 640 000	219 000	800	1 200	NA4960
320	400	80	2.1	350	2	640 000	1 850 000	153 000	750	1 100	NA4864
	440	118	3	360	2	1 120 000	2 820 000	230 000	750	1 100	NA4964
340	420	80	2.1	370	2	655 000	1 940 000	158 000	750	1 100	NA4868
	460	118	3	380	2	1 160 000	3 000 000	242 000	750	1 100	NA4968
360	440	80	2.1	390	2	665 000	2 020 000	162 000	650	1 000	NA4872
	480	118	3	400	2	1 200 000	3 200 000	253 000	650	1 000	NA4972
380	480	100	2.1	415	2	1 000 000	2 840 000	223 000	650	950	NA4876
	520	140	4	430	2	1 400 000	3 750 000	292 000	650	950	NA4976
400	540	140	4	450	2.5	1 450 000	4 000 000	305 000	600	900	NA4980
420	560	140	4	470	2.5	1 500 000	4 250 000	320 000	550	850	NA4984
440	600	160	4	490	2.5	1 750 000	4 600 000	340 000	550	800	NA4988

1) Smallest allowable dimension for chamfer dimension r.

2) Allowable axial movement amount of the inner ring with respect to the outer ring.

3) Largest allowable dimension for fillet radius r_a of housing and shaft.

Needle Roller Bearings

NTN

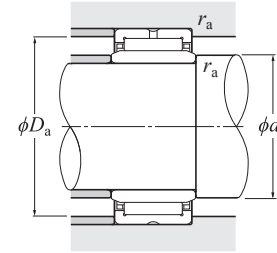

Installation-related dimensions			Mass kg (approx.)
d _a Min.	D _a Max.	r _{as} ³⁾ Max.	
311	369	2	22.0
313	407	2.5	42.5
331	389	2	23.2
333	427	2.5	45.2
351	409	2	24.1
353	447	2.5	47.3
371	429	2	25.7
373	467	2.5	49.0
391	469	2	44.5
396	504	3	73.6
416	524	3	76.6
436	544	3	89.8
456	584	3	123

Note: The number of inner rings (IR) is composed of the IR bore diameter dimension × outside diameter dimension × width dimension.

Needle Roller Bearings

Thrust cylindrical roller bearings

811 type
812 type
893 type

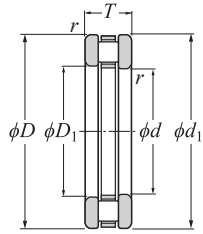

811 type
812 type
(Bearing)



893 type
(Bearing)

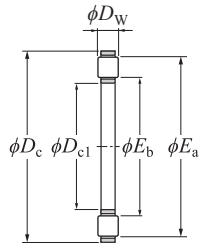

K811 type, K812 type
(Thrust cylindrical roller
and cage assembly)

d 10–60 mm

d	Boundary dimensions									Basic load rating		Fatigue load limit N C _u	Allowable speed	
	D	d ₁	D ₁	T	mm D _{c1} ²⁾ E11	D _c a13	D _w 0 -0.010	B h11	r _{s min} ¹⁾	dynamic C _a	static N C _{0a}		Grease min ⁻¹	Oil lubrication
10	24	24	10	9	10	24	3.5	2.75	0.3	10 300	20 100	2 450	3 400	13 000
12	26	26	12	9	12	26	3.5	2.75	0.3	10 900	22 300	2 720	3 000	12 000
15	28	28	16	9	15	28	3.5	2.75	0.3	12 200	26 800	3 250	2 800	11 000
17	30	30	18	9	17	30	3.5	2.75	0.3	12 700	29 000	3 550	2 500	10 000
20	35	35	21	10	20	35	4.5	2.75	0.3	20 200	46 500	5 650	2 100	8 500
25	42	42	26	11	25	42	5	3	0.6	27 300	68 000	8 250	1 800	7 000
30	47	47	32	11	30	47	5	3	0.6	27 800	72 500	8 850	1 500	6 000
	52	52	32	16	30	52	7.5	4.25	0.6	53 000	129 000	15 700	1 500	6 000
	60	60	32	18	30	60	5.5	6.25	1	54 000	166 000	20 200	1 300	5 000
35	52	52	37	12	35	52	5	3.5	0.6	31 000	87 000	10 600	1 400	5 500
	62	62	37	18	35	62	7.5	5.25	1	54 500	139 000	17 000	1 200	4 900
	68	68	37	20	35	68	6	7	1	66 500	214 000	26 100	1 200	4 600
40	60	60	42	13	40	60	6	3.5	0.6	43 000	121 000	14 800	1 200	4 800
	68	68	42	19	40	68	9	5	1	74 500	190 000	23 200	1 100	4 400
	78	78	42	22	40	78	7	7.5	1	85 000	277 000	34 000	1 000	4 000
45	65	65	47	14	45	65	6	4	0.6	45 500	135 000	16 500	1 100	4 400
	73	73	47	20	45	73	9	5.5	1	82 000	222 000	27 000	1 000	4 100
	85	85	47	24	45	85	7.5	8.25	1	102 000	345 000	42 000	900	3 600
50	70	70	52	14	50	70	6	4	0.6	48 500	150 000	18 300	1 000	4 000
	78	78	52	22	50	78	9	6.5	1	85 000	238 000	29 000	950	3 800
	95	95	52	27	50	95	8	9.5	1.1	125 000	445 000	54 000	800	3 200
55	78	78	57	16	55	78	6	5	0.6	62 500	215 000	26 200	900	3 600
	90	90	57	25	55	90	11	7	1	121 000	340 000	41 500	830	3 300
	105	105	57	30	55	105	9	10.5	1.1	158 000	570 000	69 500	730	2 900
60	85	85	62	17	60	85	7.5	4.75	1	69 000	215 000	26 200	830	3 300
	95	95	62	26	60	95	11	7.5	1	126 000	365 000	44 500	780	3 100
	110	110	62	30	60	110	9	10.5	1.1	162 000	600 000	73 500	680	2 700

1) Smallest allowable dimension for chamfer dimension r.
2) The tolerance of bearings with suffix code T2 is E12.

Needle Roller Bearings

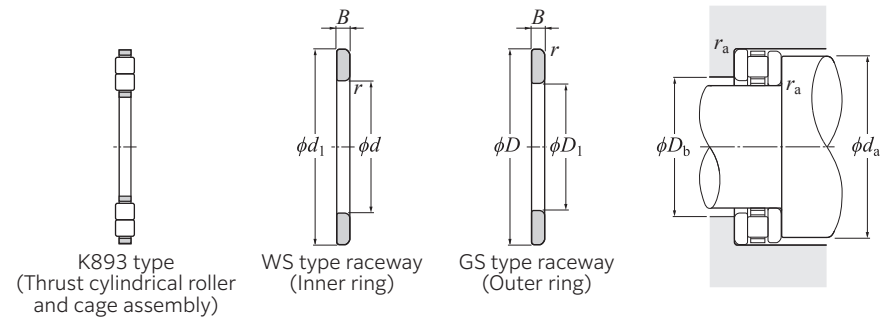

K893 type
(Thrust cylindrical roller
and cage assembly)

WS type raceway
(Inner ring)

GS type raceway
(Outer ring)

Number	Approx. dimension mm	Installation-related dimensions			Mass							
		d _a	D _b	r _{as}	kg (approx.)							
Bearing	E _b	E _a	Min.	Max.	811	K811 K893	WS811 WS893	GS811 GS812 GS811 GS812 GS893				
81100T2	K81100T2	WS81100	GS81100	13.5	21.3	21	14	0.3	0.020	0.0035	0.0081	0.0081
81101T2	K81101T2	WS81101	GS81101	15.5	23.3	23	16	0.3	0.022	0.0040	0.0090	0.0090
81102T2	K81102T2	WS81102	GS81102	17.2	25	25	18	0.3	0.024	0.0060	0.0095	0.0090
81103T2	K81103T2	WS81103	GS81103	19.2	27	27	20	0.3	0.028	0.0080	0.010	0.010
81104T2	K81104T2	WS81104	GS81104	22.4	32.3	32	23	0.3	0.039	0.012	0.014	0.013
81105T2	K81105T2	WS81105	GS81105	27.6	38.7	39	28	0.6	0.059	0.018	0.021	0.020
81106T2	K81106T2	WS81106	GS81106	33.1	43.9	44	33	0.6	0.066	0.020	0.024	0.022
81206T2	K81206T2	WS81206	GS81206	32.8	49	48	33	0.6	0.141	0.050	0.047	0.044
89306	K89306	WS89306	GS89306	34	56.4	56	34	1	0.249	0.046	0.104	0.099
81107T2	K81107T2	WS81107	GS81107	38	48.9	49	38	0.6	0.085	0.024	0.032	0.029
81207T2	K81207T2	WS81207	GS81207	39.8	56	56	41	1	0.230	0.065	0.085	0.080
89307	K89307	WS89307	GS89307	40	64.4	64	40	1	0.351	0.064	0.147	0.140
81108T2	K81108T2	WS81108	GS81108	43.2	56.4	56	44	0.6	0.118	0.035	0.043	0.040
81208T2	K81208T2	WS81208	GS81208	43.7	62.9	63	44	1	0.266	0.085	0.093	0.088
89308	K89308	WS89308	GS89308	46	74.4	74	46	1	0.507	0.100	0.207	0.200
81109T2	K81109T2	WS81109	GS81109	48.4	61.6	61	49	0.6	0.144	0.040	0.054	0.050
81209T2	K81209T2	WS81209	GS81209	48.8	68	68	49	1	0.318	0.100	0.112	0.106
89309	K89309	WS89309	GS89309	50.9	81.3	81	51	1	0.660	0.140	0.264	0.255
81110T2	K81110T2	WS81110	GS81110	53.2	66.4	66	54	0.6	0.158	0.045	0.059	0.054
81210T2	K81210T2	WS81210	GS81210	53.7	73.1	73	54	1	0.384	0.105	0.144	0.135
89310	K89310	WS89310	GS89310	58	90.4	90	58	1	0.932	0.180	0.382	0.370
81111T2	K81111T2	WS81111	GS81111	57.8	75.2	75	58	0.6	0.242	0.060	0.094	0.087
81211T2	K81211T2	WS81211	GS81211	60.1	83.4	83	61	1	0.618	0.190	0.219	0.209
89311	K89311	WS89311	GS89311	63.9	100.3	100	64	1	1.26	0.240	0.518	0.503
81112T2	K81112T2	WS81112	GS81112	63.7	80.1	80	65	1	0.288	0.083	0.106	0.099
81212T2	K81212T2	WS81212	GS81212	64.9	88.4	88	66	1	0.690	0.200	0.251	0.240
89312	K89312	WS89312	GS89312	68.9	105.3	105	69	1	1.33	0.250	0.550	0.534

Needle Roller Bearings

Thrust cylindrical roller bearings

811 type
812 type
893 type

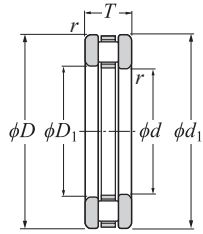

811 type
812 type
(Bearing)



893 type
(Bearing)

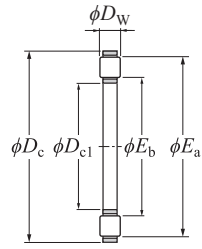

K811 type, K812 type
(Thrust cylindrical roller
and cage assembly)

d 65–130 mm

d	Boundary dimensions										Basic load rating		Fatigue load limit N C _u	Allowable speed	
	D	d ₁	D ₁	T	mm D _{c1} ²⁾ E11	D _c a13	D _w 0 -0.010	B h11	r _s min ¹⁾	dynamic C _a	static N C _{0a}	min ⁻¹ Grease lubrication		Oil lubrication	
65	90	90	67	18	65	90	7.5	5.25	1	73 000	236 000	28 800	780	3 100	
	100	100	67	27	65	100	11	8	1	130 000	385 000	47 000	730	2 900	
	115	115	67	30	65	115	9	10.5	1.1	167 000	635 000	77 500	650	2 600	
70	95	95	72	18	70	95	7.5	5.25	1	76 500	257 000	31 500	730	2 900	
	105	105	72	27	70	105	11	8	1	134 000	410 000	50 000	680	2 700	
	125	125	72	34	70	125	10	12	1.1	205 000	790 000	96 500	600	2 400	
75	100	100	77	19	75	100	7.5	5.75	1	78 000	268 000	32 500	680	2 700	
	110	110	77	27	75	110	11	8	1	138 000	435 000	53 000	650	2 600	
	135	135	77	36	75	135	11	12.5	1.5	239 000	920 000	110 000	550	2 200	
80	105	105	82	19	80	105	7.5	5.75	1	79 500	279 000	34 000	650	2 600	
	115	115	82	28	80	115	11	8.5	1	143 000	460 000	56 000	630	2 500	
	140	140	82	36	80	140	11	12.5	1.5	246 000	970 000	114 000	530	2 100	
85	110	110	87	19	85	110	7.5	5.75	1	83 000	300 000	36 500	630	2 500	
	125	125	88	31	85	125	12	9.5	1	169 000	550 000	66 500	580	2 300	
	150	150	88	39	85	150	12	13.5	1.5	281 000	1 100 000	128 000	500	2 000	
90	120	120	92	22	90	120	9	6.5	1	112 000	395 000	47 500	580	2 300	
	135	135	93	35	90	135	14	10.5	1.1	213 000	680 000	80 000	530	2 100	
	155	155	93	39	90	155	12	13.5	1.5	289 000	1 160 000	132 000	480	1 900	
100	135	135	102	25	100	135	11	7	1	158 000	555 000	65 000	500	2 000	
	150	150	103	38	100	150	15	11.5	1.1	243 000	795 000	91 000	480	1 900	
	170	170	103	42	100	170	13	14.5	1.5	335 000	1 370 000	153 000	430	1 700	
110	145	145	112	25	110	145	11	7	1	165 000	605 000	68 500	480	1 900	
	160	160	113	38	110	160	15	11.5	1.1	258 000	885 000	98 500	450	1 800	
	190	190	113	48	110	190	15	16.5	2	430 000	1 770 000	190 000	400	1 600	
120	155	155	122	25	120	155	11	7	1	172 000	655 000	72 500	450	1 800	
	170	170	123	39	120	170	15	12	1.1	264 000	930 000	101 000	430	1 700	
130	170	170	132	30	130	170	12	9	1	197 000	755 000	81 500	400	1 600	
	190	187	133	45	130	190	19	13	1.5	360 000	1 210 000	128 000	380	1 500	

1) Smallest allowable dimension for chamfer dimension r.
2) The tolerance of bearings with suffix code T2 is E12.

Needle Roller Bearings

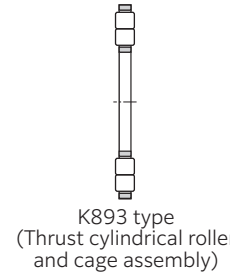

K893 type
(Thrust cylindrical roller
and cage assembly)

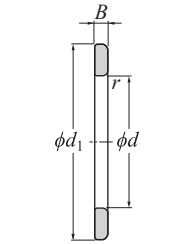

WS type raceway
(Inner ring)

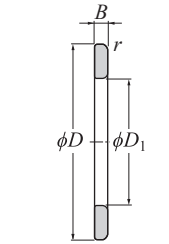

GS type raceway
(Outer ring)

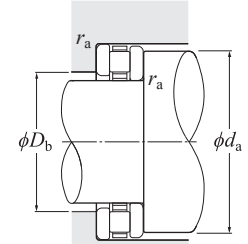

Bearing	Number			Approx. dimension mm		Installation-related dimensions mm			Mass kg (approx.)			
	Thrust cylindrical roller and cage assembly	Inner ring	Outer ring	E _b	E _a	d _a	D _b	r _{as}	811	K811 K812 K893	WS811 WS812 WS893	GS811 GS812 GS893
81113T2 81213T2 89313	K81113T2 K81213T2 K89313	WS81113 WS81213 WS89313	GS81113 GS81213 GS89313	68.8	85.2	85	70	1	0.332	0.090	0.125	0.117
				69.9	93.3	93	71	1	0.772	0.215	0.285	0.272
				73.9	110.3	110	74	1	1.41	0.260	0.583	0.566
81114T2 81214T2 89314	K81114T2 K81214T2 K89314	WS81114 WS81214 WS89314	GS81114 GS81214 GS89314	73.7	90.1	90	74	1	0.355	0.097	0.134	0.124
				75	98.4	98	76	1	0.815	0.225	0.302	0.288
				79.8	120.2	120	80	1	1.91	0.340	0.793	0.772
81115T2 81215T2 89315	K81115T2 K81215T2 K89315	WS81115 WS81215 WS89315	GS81115 GS81215 GS89315	78.7	95.1	95	80	1	0.414	0.115	0.155	0.144
				80.1	103.7	103	81	1	0.864	0.240	0.319	0.304
				84.7	129.2	129	85	1.5	2.39	0.470	0.971	0.948
81116T2 81216T2 89316	K81116T2 K81216T2 K89316	WS81116 WS81216 WS89316	GS81116 GS81216 GS89316	83.7	100.1	100	85	1	0.435	0.119	0.164	0.152
				84.8	108.4	106	86	1	0.948	0.250	0.358	0.341
				89.8	134.2	134	90	1.5	2.50	0.490	1.02	0.992
81117T2 81217 89317	K81117T2 K81217 K89317	WS81117 WS81217 WS89317	GS81117 GS81217 GS89317	88.7	105.3	105	89	1	0.458	0.125	0.173	0.161
				92.2	116.9	116	92	1	1.25	0.300	0.492	0.462
				95.8	144.2	144	96	1.5	3.09	0.590	1.27	1.23
81118T2 81218J 89318	K81118T2 K81218J K89318	WS81118 WS81218 WS89318	GS81118 GS81218 GS89318	94.7	114.3	114	95	1	0.660	0.170	0.252	0.238
				97.9	126.7	126	97	1	1.82	0.540	0.655	0.620
				100.8	149.2	149	101	1.5	3.23	0.620	1.33	1.28
81120T2 81220 89320	K81120T2 K81220 K89320	WS81120 WS81220 WS89320	GS81120 GS81220 GS89320	105.1	128.7	128	106	1	0.993	0.300	0.355	0.338
				109.2	140	139	109	1	2.35	0.620	0.886	0.843
				110.6	163	163	110	1.5	4.13	0.810	1.69	1.64
81122T2 81222 89322	K81122T2 K81222 K89322	WS81122 WS81222 WS89322	GS81122 GS81222 GS89322	115	138.8	138	116	1	1.08	0.325	0.385	0.366
				119.2	150	149	119	1	2.55	0.685	0.957	0.910
				122.5	183	183	122	2	5.96	1.15	2.44	2.37
81124T2 81224	K81124T2 K81224	WS81124 WS81224	GS81124 GS81224	125	148.8	148	126	1	1.15	0.340	0.415	0.395
				129.2	160	159	129	1	2.82	0.730	1.07	1.02
81126 81226	K81126 K81226	WS81126 WS81226	GS81126 GS81226	137.7	162.4	162	137	1	1.72	0.415	0.666	0.637
				140.1	179	178	140	1.5	4.06	1.14	1.45	1.48

Needle Roller Bearings



Thrust cylindrical roller bearings

811 type
812 type

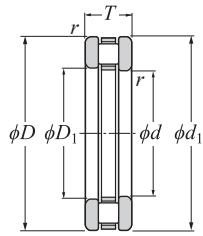

811 type
812 type
(Bearing)

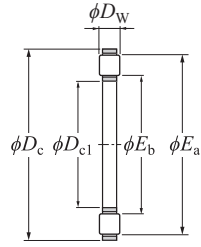

K811 type, K812 type
(Thrust cylindrical roller
and cage assembly)

d 140–160 mm

d	Boundary dimensions										Basic load rating		Fatigue load limit N Cu	Allowable speed	
	D	d ₁	D ₁	T	mm		B	r _s min ¹⁾	dynamic	static	Grease lubrication	Oil lubrication			
	E11	a13	0	-0.010	h11	Ca			Coa	min ⁻¹					
140	180	178	142	31	140	180	12	9.5	1	206 000	815 000	86 000	380	1 500	
	200	197	143	46	140	200	19	13.5	1.5	370 000	1 280 000	133 000	350	1 400	
150	190	188	152	31	150	190	12	9.5	1	214 000	870 000	90 500	350	1 400	
160	200	198	162	31	160	200	12	9.5	1	221 000	930 000	95 000	330	1 300	

Needle Roller Bearings

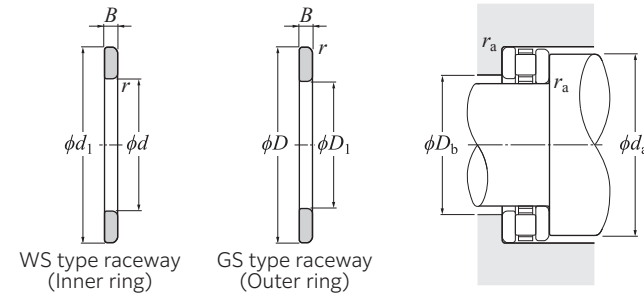

Bearing	Number			Approx. dimension mm		Installation-related dimensions mm			Mass kg (approx.)			
	Thrust cylindrical roller and cage assembly	Inner ring	Outer ring	Eb	Ea	da	Db	ras	811 K811 WS811 GS811			
									K812 WS812 GS812			
81128	K81128	WS81128	GS81128	147.8	172.5	172	147	1	1.87	0.450	0.708	0.717
81228	K81228	WS81228	GS81228	150.1	189	188	150	1.5	4.43	1.20	1.60	1.63
81130	K81130	WS81130	GS81130	157.7	182.4	182	157	1	1.98	0.470	0.752	0.761
81132	K81132	WS81132	GS81132	167.8	192.5	192	167	1	2.10	0.500	0.797	0.806

1) Smallest allowable dimension for chamfer dimension r.

Needle Roller Bearings



Thrust needle roller bearings

AXK11 type
AS11 type
WS811 type
GS811 type

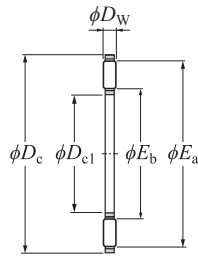

AXK type
(Thrust needle roller
and cage assembly)

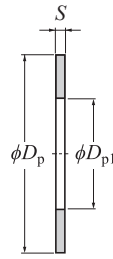

AS type raceway
(Washer)

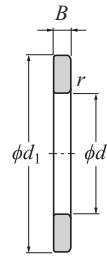

WS type raceway
(Inner ring)

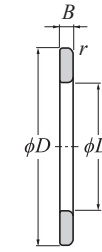

GS type raceway
(Outer ring)

D_{c1} 10–140 mm

Boundary dimensions												Basic load rating		Fatigue load limit N C_u	
D_{c1} E11	D_c c12	D_w 0 -0.010	D_p e13	D_{p1} E12	S^2 ± 0.05	mm				r_s min ¹⁾	dynamic N C_a	static C_{0a}			
						d	d_1	D	D_1	B					
10	24	2	24	10	1	10	24	24	10	2.75	0 -0.060	0.3	9 150	25 300	3 100
12	26	2	26	12	1	12	26	26	12	2.75	0 -0.060	0.3	9 850	28 900	3 500
15	28	2	28	15	1	15	28	28	16	2.75	0 -0.060	0.3	11 300	36 000	4 400
17	30	2	30	17	1	17	30	30	18	2.75	0 -0.060	0.3	11 900	39 500	4 800
20	35	2	35	20	1	20	35	35	21	2.75	0 -0.060	0.3	13 200	46 500	5 650
25	42	2	42	25	1	25	42	42	26	3	0 -0.060	0.6	14 600	58 000	7 050
30	47	2	47	30	1	30	47	47	32	3	0 -0.060	0.6	16 300	69 500	8 500
35	52	2	52	35	1	35	52	52	37	3.5	0 -0.075	0.6	17 800	81 500	9 900
40	60	3	60	40	1	40	60	60	42	3.5	0 -0.075	0.6	27 400	110 000	13 500
45	65	3	65	45	1	45	65	65	47	4	0 -0.075	0.6	29 800	128 000	15 600
50	70	3	70	50	1	50	70	70	52	4	0 -0.075	0.6	31 500	143 000	17 400
55	78	3	78	55	1	55	78	78	57	5	0 -0.075	0.6	38 000	186 000	22 700
60	85	3	85	60	1	60	85	85	62	4.75	0 -0.075	1	44 500	234 000	28 600
65	90	3	90	65	1	65	90	90	67	5.25	0 -0.075	1	46 500	254 000	31 000
70	95	4	95	70	1	70	95	95	72	5.25	0 -0.075	1	53 500	253 000	31 000
75	100	4	100	75	1	75	100	100	77	5.75	0 -0.075	1	55 000	266 000	32 500
80	105	4	105	80	1	80	105	105	82	5.75	0 -0.075	1	56 500	279 000	34 000
85	110	4	110	85	1	85	110	110	87	5.75	0 -0.075	1	57 500	291 000	35 500
90	120	4	120	90	1	90	120	120	92	6.5	0 -0.090	1	70 500	390 000	46 500
100	135	4	135	100	1	100	135	135	102	7	0 -0.090	1	90 000	550 000	64 000
110	145	4	145	110	1	110	145	145	112	7	0 -0.090	1	93 500	590 000	67 000
120	155	4	155	120	1	120	155	155	122	7	0 -0.090	1	99 000	650 000	72 000
130	170	5	170	130	1	130	170	170	132	9	0 -0.090	1	140 000	900 000	97 000
140	180	5	180	140	1	140	178	180	142	9.5	0 -0.090	1	145 000	960 000	102 000

1) Smallest allowable dimension for chamfer dimension r .
2) The measured load is 2.04 N or above.

Needle Roller Bearings



Allowable speed min^{-1} Grease lubrication Oil lubrication	Number				Approx. dimension mm		Mass kg (approx.)				
	Thrust needle roller and cage assembly	Washer	Inner ring	Outer ring	E_b	E_a	AXK11	AS11	WS811 WS812 WS893	GS811 GS812 GS893	
3 500	14 000	AXK1100	AS1100	WS81100	GS81100	12.3	21.7	0.0028	0.0029	0.0081	0.0081
3 300	13 000	AXK1101	AS1101	WS81101	GS81101	14.3	23.7	0.0030	0.0033	0.0090	0.0090
2 800	11 000	AXK1102	AS1102	WS81102	GS81102	17.2	26.5	0.0035	0.0034	0.0095	0.0090
2 500	10 000	AXK1103	AS1103	WS81103	GS81103	19.2	28.5	0.0040	0.0038	0.010	0.010
2 100	8 500	AXK1104	AS1104	WS81104	GS81104	21.3	31.3	0.0050	0.0051	0.014	0.013
1 800	7 000	AXK1105	AS1105	WS81105	GS81105	29.5	39.4	0.0070	0.0070	0.021	0.020
1 500	6 000	AXK1106	AS1106	WS81106	GS81106	34.5	44.4	0.0080	0.0081	0.024	0.022
1 400	5 500	AXK1107	AS1107	WS81107	GS81107	39.5	49.4	0.010	0.0091	0.032	0.029
1 200	4 700	AXK1108	AS1108	WS81108	GS81108	44.2	56.2	0.019	0.012	0.043	0.040
1 100	4 300	AXK1109	AS1109	WS81109	GS81109	50.5	62.4	0.021	0.014	0.054	0.050
1 000	3 900	AXK1110	AS1110	WS81110	GS81110	55.5	67.4	0.024	0.015	0.059	0.054
900	3 500	AXK1111	AS1111	WS81111	GS81111	61.0	74.9	0.031	0.019	0.094	0.087
800	3 200	AXK1112	AS1112	WS81112	GS81112	66.0	81.9	0.039	0.022	0.106	0.099
750	3 000	AXK1113	AS1113	WS81113	GS81113	71.0	86.9	0.040	0.024	0.125	0.117
750	2 900	AXK1114	AS1114	WS81114	GS81114	75.5	91.4	0.060	0.025	0.134	0.124
700	2 700	AXK1115	AS1115	WS81115	GS81115	80.5	96.4	0.061	0.027	0.155	0.144
650	2 600	AXK1116	AS1116	WS81116	GS81116	84.4	100.3	0.063	0.029	0.164	0.152
600	2 400	AXK1117	AS1117	WS81117	GS81117	90.5	106.4	0.067	0.030	0.173	0.161
600	2 300	AXK1118	AS1118	WS81118	GS81118	96.5	116.4	0.086	0.039	0.252	0.238
500	2 000	AXK1120	AS1120	WS81120	GS81120	107.5	131.4	0.112	0.051	0.355	0.338
480	1 900	AXK1122	AS1122	WS81122	GS81122	115.5	139.4	0.122	0.055	0.385	0.366
430	1 700	AXK1124	AS1124	WS81124	GS81124	125.5	149.4	0.131	0.059	0.415	0.395
400	1 600	AXK1126	AS1126	WS81126	GS81126	136.0	164.0	0.205	0.074	0.666	0.637
380	1 500	AXK1128	AS1128	WS81128	GS81128	146.0	174.0	0.219	0.079	0.708	0.717

Needle Roller Bearings

Thrust needle roller bearings

- AXK11 type
- AS11 type
- WS811 type
- GS811 type

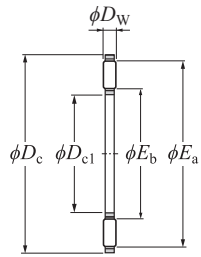

AXK type
(Thrust needle roller
and cage assembly)

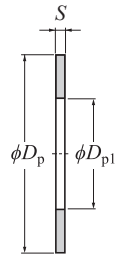

AS type raceway
(Washer)

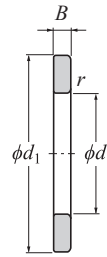

WS type raceway
(Inner ring)

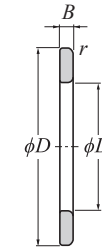

GS type raceway
(Outer ring)

D_{c1} 150–160 mm

Boundary dimensions												Basic load rating		Fatigue load limit N C_u	
D_{c1} E11	D_c c12	D_w 0 -0.010	D_p e13	D_{p1} E12	$S^2)$ ± 0.05	mm				B	$r_{s \min^1)$	dynamic N C_a	static N C_{0a}		
						d	d_1	D	D_1						
150	190	5	190	150	1	150	188	190	152	9.5	0 -0.090	1	149 000	1 020 000	106 000
160	200	5	200	160	1	160	198	200	162	9.5	0 -0.090	1	154 000	1 070 000	110 000

Needle Roller Bearings

Allowable speed		Number				Approx. dimension		Mass				
Grease lubrication	Oil lubrication	Thrust needle roller and cage assembly		Washer	Inner ring	Outer ring	E_b	E_a	kg (approx.)			
									AXK11	AS11	WS811 WS812 WS893	GS811 GS812 GS893
350	1 400	AXK1130	AS1130	WS81130	GS81130	156.0	184.2	0.232	0.084	0.752	0.761	
330	1 300	AXK1132	AS1132	WS81132	GS81132	166.0	194.2	0.246	0.089	0.797	0.806	

1) Smallest allowable dimension for chamfer dimension r .
2) The measured load is 2.04 N or above.

Needle Roller Bearings



Cam follower stud type track roller metric series

- KR···H type
- KR···XH type
- KR···LLH type
- KR···XLLH type

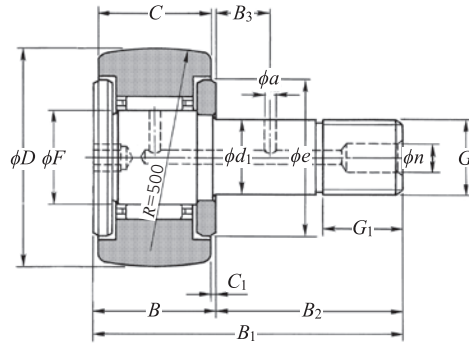
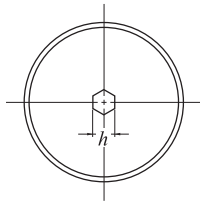

KR···H type (With cage)

D 10–90 mm

Outside dia. ¹⁾ mm D 0 -0.05	Dimensions mm														Basic load rating		Fatigue load limit N Cu
	d ₁	C	F	B	B ₁	B ₂	G	G ₁	B ₃	C ₁	n	a	e	h	C _r	C _{0r}	
10	3 ⁰ _{-0.010}	7	4	8	17	9	M 3×0.5	5	—	0.5	—	—	7	2.5	1 640	1 270	155
12	4 ⁰ _{-0.012}	8	4.8	9	20	11	M 4×0.7	6	—	0.5	—	—	8.5	2.5	2 170	1 690	206
13	5 ⁰ _{-0.012}	9	5.75	10	23	13	M 5×0.8	7.5	—	0.5	—	—	9.5	3	2 650	2 260	276
16	6 ⁰ _{-0.012}	11	8	12	28	16	M 6×1	8	—	0.6	—	—	12	3	4 050	4 200	510
19	8 ⁰ _{-0.015}	11	10	12	32	20	M 8×1.25	10	—	0.6	—	—	14	4	4 750	5 400	660
22	10 ⁰ _{-0.015}	12	12	13	36	23	M10×1.25	12	—	0.6	4	—	17	4	5 300	6 650	810
26	10 ⁰ _{-0.015}	12	12	13	36	23	M10×1.25	12	—	0.6	4	—	17	4	5 300	6 650	810
30	12 ⁰ _{-0.018}	14	15	15	40	25	M12×1.5	13	6	0.6	6	3	23	6	7 850	9 650	1 180
32	12 ⁰ _{-0.018}	14	15	15	40	25	M12×1.5	13	6	0.6	6	3	23	6	7 850	9 650	1 180
35	16 ⁰ _{-0.018}	18	18	19.5	52	32.5	M16×1.5	17	8	0.8	6	3	27	6	12 200	17 900	2 180
40	18 ⁰ _{-0.018}	20	22	21.5	58	36.5	M18×1.5	19	8	0.8	6	3	32	6	14 000	22 800	2 790
47	20 ⁰ _{-0.021}	24	25	25.5	66	40.5	M20×1.5	21	9	0.8	8	4	37	8	20 700	33 500	4 100
52	20 ⁰ _{-0.021}	24	25	25.5	66	40.5	M20×1.5	21	9	0.8	8	4	37	8	20 700	33 500	4 100
62	24 ⁰ _{-0.021}	29	30	30.5	80	49.5	M24×1.5	25	11	0.8	8	4	44	8	28 900	55 000	6 700
72	24 ⁰ _{-0.021}	29	30	30.5	80	49.5	M24×1.5	25	11	0.8	8	4	44	8	28 900	55 000	6 700
80	30 ⁰ _{-0.021}	35	38	37	100	63	M30×1.5	32	15	1	8	4	53	8	45 000	88 500	10 800
85	30 ⁰ _{-0.021}	35	38	37	100	63	M30×1.5	32	15	1	8	4	53	8	45 000	88 500	10 800
90	30 ⁰ _{-0.021}	35	38	37	100	63	M30×1.5	32	15	1	8	4	53	8	45 000	88 500	10 800

1) The tolerance of outer ring outside diameter D of KR···XH type and KR···XLLH type having a cylindrical outside diameter surface is JIS Class 0.

Needle Roller Bearings

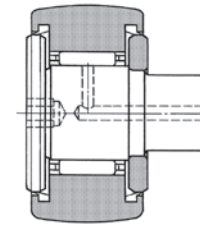

KR···LLH type (Seal type with cage)

Accessories

Applied bearing number	Grease nipple number	Plug number	Applied hexagonal nut
10 to 19	—	—	1M 3×0.5 to 1M 8×1.25
22 to 26	NIP-B4	SEN4	1M10×1.25
30 to 40	NIP-B6	SEN3, SEN6	1M12×1.5 to 1M18×1.5
47 to 90	NIP-B8	SEN4, SEN8	1M20×1.5 to 1M30×1.5



Grease fitting

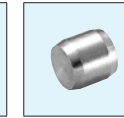

Plug

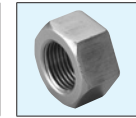

Hexagon nut

Track load capacity		Allowable speed ²⁾		Maximum tightening torque N·m	Number ³⁾				Mass kg (approx.)	Stud dia. mm
N	min ⁻¹	Grease lubrication	Oil lubrication		Spherical outer ring	Cylindrical outer ring	Spherical outer ring	Cylindrical outer ring		
560	1 360	*27 000	*40 000	0.5	KR10T2H/3AS	KR10XT2H/3AS	KR10T2LLH/3AS	KR10XT2LLH/3AS	0.005	3
725	1 790	*25 000	*36 000	1	KR12T2H/3AS	KR12XT2H/3AS	KR12T2LLH/3AS	KR12XT2LLH/3AS	0.008	4
805	2 220	*23 000	*33 000	2	KR13T2H/3AS	KR13XT2H/3AS	KR13T2LLH/3AS	KR13XT2LLH/3AS	0.010	5
1 080	3 400	*19 000	*25 000	3	KR16FDOH/L588	KR16FXDOH/L588	KR16FLDOH/L588	KR16FXLDOH/L588	0.019	6
1 380	4 050	*15 000	*20 000	8	KR19FDOH/L588	KR19FXDOH/L588	KR19FLDOH/L588	KR19FXLDOH/L588	0.031	8
1 690	5 150	*12 000	*16 000	14	KR22FH	KR22FXH	KR22FLLH/3AS	KR22FXLLH/3AS	0.046	10
2 120	6 100	*12 000	*16 000	14	KR26FH	KR26FXH	KR26FLLH/3AS	KR26FXLLH/3AS	0.059	10
2 620	7 700	10 000	*13 000	20	KR30H	KR30XH	KR30LLH/3AS	KR30XLLH/3AS	0.087	12
2 860	8 200	10 000	*13 000	20	KR32H	KR32XH	KR32LLH/3AS	KR32XLLH/3AS	0.097	12
3 200	11 900	8 000	*11 000	52	KR35H	KR35XH	KR35LLH/3AS	KR35XLLH/3AS	0.169	16
3 850	14 500	7 000	9 000	76	KR40H	KR40XH	KR40LLH/3AS	KR40XLLH/3AS	0.248	18
4 700	21 000	6 000	8 000	98	KR47H	KR47XH	KR47LLH/3AS	KR47XLLH/3AS	0.386	20
5 550	23 300	6 000	8 000	98	KR52H	KR52XH	KR52LLH/3AS	KR52XLLH/3AS	0.461	20
6 950	34 500	5 000	6 500	178	KR62H	KR62XH	KR62LLH/3AS	KR62XLLH/3AS	0.790	24
8 050	38 500	5 000	6 500	178	KR72H	KR72XH	KR72LLH/3AS	KR72XLLH/3AS	1.04	24
9 800	53 000	4 000	5 500	360	KR80H	KR80XH	KR80LLH/3AS	KR80XLLH/3AS	1.55	30
10 400	56 000	4 000	5 500	360	KR85H	KR85XH	KR85LLH/3AS	KR85XLLH/3AS	1.74	30
11 400	59 000	4 000	5 500	360	KR90H	KR90XH	KR90LLH/3AS	KR90XLLH/3AS	1.95	30

2) The allowable speed of KR···LLH type and KR···XLLH type with a "*" mark seal is about 10 000 min⁻¹.

3) Bearings having T2 after the bearing number have a resin cage, and the allowable temperature is 120 °C and 100 °C or below for continuous use.

Needle Roller Bearings



Cam follower stud type track roller metric series

- KR type
- KR·X type
- KR·LL type
- KR·XLL type

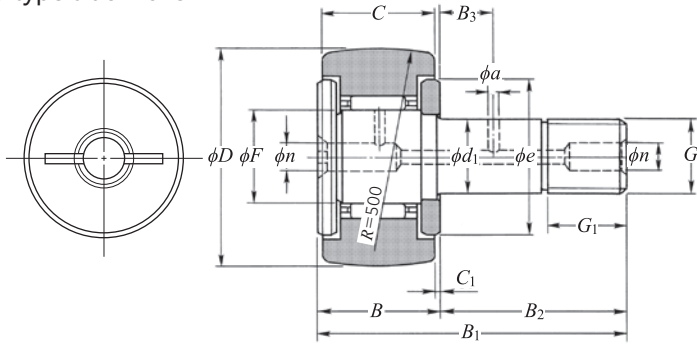

KR type (With cage)

D 16-90 mm

Outside dia. ¹⁾ mm D 0 -0.05	Dimensions mm													Basic load rating		Fatigue load limit N Cu
	d ₁	C	F	B	B ₁	B ₂	G	G ₁	B ₃	C ₁	n	a	e	C _r	C _{0r}	
16	6 ⁰ _{-0.012}	11	8	12	28	16	M 6×1	8	—	0.6	4 ²⁾	—	12	4 050	4 200	510
19	8 ⁰ _{-0.015}	11	10	12	32	20	M 8×1.25	10	—	0.6	4 ²⁾	—	14	4 750	5 400	660
22	10 ⁰ _{-0.015}	12	12	13	36	23	M10×1.25	12	—	0.6	4	—	17	5 300	6 650	810
26	10 ⁰ _{-0.015}	12	12	13	36	23	M10×1.25	12	—	0.6	4	—	17	5 300	6 650	810
30	12 ⁰ _{-0.018}	14	15	15	40	25	M12×1.5	13	6	0.6	6	3	23	7 850	9 650	1 180
32	12 ⁰ _{-0.018}	14	15	15	40	25	M12×1.5	13	6	0.6	6	3	23	7 850	9 650	1 180
35	16 ⁰ _{-0.018}	18	18	19.5	52	32.5	M16×1.5	17	8	0.8	6	3	27	12 200	17 900	2 180
40	18 ⁰ _{-0.018}	20	22	21.5	58	36.5	M18×1.5	19	8	0.8	6	3	32	14 000	22 800	2 780
47	20 ⁰ _{-0.021}	24	25	25.5	66	40.5	M20×1.5	21	9	0.8	8	4	37	20 700	33 500	4 100
52	20 ⁰ _{-0.021}	24	25	25.5	66	40.5	M20×1.5	21	9	0.8	8	4	37	20 700	33 500	4 100
62	24 ⁰ _{-0.021}	29	30	30.5	80	49.5	M24×1.5	25	11	0.8	8	4	44	28 900	55 000	6 700
72	24 ⁰ _{-0.021}	29	30	30.5	80	49.5	M24×1.5	25	11	0.8	8	4	44	28 900	55 000	6 700
80	30 ⁰ _{-0.021}	35	38	37	100	63	M30×1.5	32	15	1	8	4	53	45 000	88 500	10 800
85	30 ⁰ _{-0.021}	35	38	37	100	63	M30×1.5	32	15	1	8	4	53	45 000	88 500	10 800
90	30 ⁰ _{-0.021}	35	38	37	100	63	M30×1.5	32	15	1	8	4	53	45 000	88 500	10 800

Needle Roller Bearings

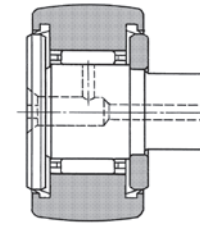

KR·LL type (Seal type with cage)

Accessories

Applied bearing number	Grease nipple number	Plug number	Applied hexagonal nut
16 to 26	NIP-B4	SEN4	1M 6×1 to 1M10×1.25
30 to 40	NIP-B6	SEN3, SEN6	1M12×1.5 to 1M18×1.5
47 to 90	NIP-B8	SEN4, SEN8	1M20×1.5 to 1M30×1.5



Grease fitting



Plug

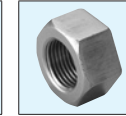

Hexagon nut

Track load capacity		Allowable speed ³⁾		Maximum tightening torque N·m	Number				Mass kg (approx.)	Stud dia. mm
N	min ⁻¹	Grease lubrication	Oil lubrication		Without seal		With seal			
Spherical outer ring	Cylindrical outer ring			Spherical outer ring	Cylindrical outer ring	Spherical outer ring	Cylindrical outer ring			
1 080	3 400	*19 000	*25 000	3	KR16F	KR16FX	KR16FLL/3AS	KR16FXLL/3AS	0.019	6
1 380	4 050	*15 000	*20 000	8	KR19F	KR19FX	KR19FLL/3AS	KR19FXLL/3AS	0.031	8
1 690	5 150	*12 000	*16 000	14	KR22F	KR22FX	KR22FLL/3AS	KR22FXLL/3AS	0.046	10
2 120	6 100	*12 000	*16 000	14	KR26F	KR26FX	KR26FLL/3AS	KR26FXLL/3AS	0.059	10
2 620	7 700	10 000	*13 000	20	KR30	KR30X	KR30LL/3AS	KR30XLL/3AS	0.087	12
2 860	8 200	10 000	*13 000	20	KR32	KR32X	KR32LL/3AS	KR32XLL/3AS	0.097	12
3 200	11 900	8 000	*11 000	52	KR35	KR35X	KR35LL/3AS	KR35XLL/3AS	0.169	16
3 850	14 500	7 000	9 000	76	KR40	KR40X	KR40LL/3AS	KR40XLL/3AS	0.248	18
4 700	21 000	6 000	8 000	98	KR47	KR47X	KR47LL/3AS	KR47XLL/3AS	0.386	20
5 550	23 300	6 000	8 000	98	KR52	KR52X	KR52LL/3AS	KR52XLL/3AS	0.461	20
6 950	34 500	5 000	6 500	178	KR62	KR62X	KR62LL/3AS	KR62XLL/3AS	0.790	24
8 050	38 500	5 000	6 500	178	KR72	KR72X	KR72LL/3AS	KR72XLL/3AS	1.04	24
9 800	53 000	4 000	5 500	360	KR80	KR80X	KR80LL/3AS	KR80XLL/3AS	1.55	30
10 400	56 000	4 000	5 500	360	KR85	KR85X	KR85LL/3AS	KR85XLL/3AS	1.74	30
11 400	59 000	4 000	5 500	360	KR90	KR90X	KR90LL/3AS	KR90XLL/3AS	1.95	30

1) The tolerance of outer ring outside diameter *D* of KR·X type and KR·XLL type having a cylindrical outside diameter surface is JIS Class 0.

2) A grease filler hole is provided only on the front surface (left side in the above drawing).

3) The allowable speed of KR·LL type and KR·XLL type with a "*" mark seal is about 10 000 min⁻¹.

Needle Roller Bearings

Cam follower stud type track roller metric series

- KRV···H type
- KRV···XH type
- KRV···LLH type
- KRV···XLLH type

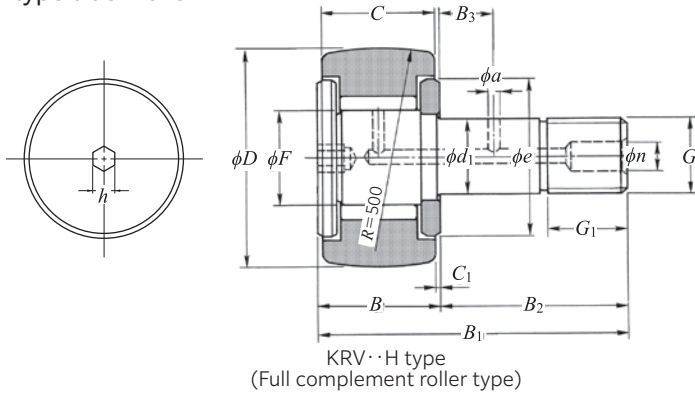

KRV···H type (Full complement roller type)

D 10–90 mm

Outside dia. ¹⁾ mm D 0 -0.05	Dimensions mm													Basic load rating		Fatigue load limit N Cu	
	d ₁	C	F	B	B ₁	B ₂	G	G ₁	B ₃	C ₁	n	a	e	h	dynamic N C _r		static N C _{0r}
10	3 ⁰ _{-0.010}	7	4	8	17	9	M 3×0.5	5	—	0.5	—	—	7	2.5	2 500	2 610	320
12	4 ⁰ _{-0.012}	8	4.8	9	20	11	M 4×0.7	6	—	0.5	—	—	8.5	2.5	3 500	3 800	460
13	5 ⁰ _{-0.012}	9	5.75	10	23	13	M 5×0.8	7.5	—	0.5	—	—	9.5	3	4 500	5 350	650
16	6 ⁰ _{-0.012}	11	8	12	28	16	M 6×1	8	—	0.6	—	—	12	3	6 500	9 350	1 140
19	8 ⁰ _{-0.015}	11	10	12	32	20	M 8×1.25	10	—	0.6	—	—	14	4	7 450	11 700	1 430
22	10 ⁰ _{-0.015}	12	12	13	36	23	M10×1.25	12	—	0.6	4	—	17	4	8 200	14 000	1 700
26	10 ⁰ _{-0.015}	12	12	13	36	23	M10×1.25	12	—	0.6	4	—	17	4	8 200	14 000	1 700
30	12 ⁰ _{-0.018}	14	15	15	40	25	M12×1.5	13	6	0.6	6	3	23	6	12 000	20 300	2 470
32	12 ⁰ _{-0.018}	14	15	15	40	25	M12×1.5	13	6	0.6	6	3	23	6	12 000	20 300	2 470
35	16 ⁰ _{-0.018}	18	18	19.5	52	32.5	M16×1.5	17	8	0.8	6	3	27	6	17 600	34 000	4 150
40	18 ⁰ _{-0.018}	20	22	21.5	58	36.5	M18×1.5	19	8	0.8	6	3	32	6	19 400	42 000	5 100
47	20 ⁰ _{-0.021}	24	25	25.5	66	40.5	M20×1.5	21	9	0.8	8	4	37	8	28 800	61 000	7 450
52	20 ⁰ _{-0.021}	24	25	25.5	66	40.5	M20×1.5	21	9	0.8	8	4	37	8	28 800	61 000	7 450
62	24 ⁰ _{-0.021}	29	30	30.5	80	49.5	M24×1.5	25	11	0.8	8	4	44	8	39 500	98 500	12 000
72	24 ⁰ _{-0.021}	29	30	30.5	80	49.5	M24×1.5	25	11	0.8	8	4	44	8	39 500	98 500	12 000
80	30 ⁰ _{-0.021}	35	38	37	100	63	M30×1.5	32	15	1	8	4	53	8	58 000	147 000	18 000
90	30 ⁰ _{-0.021}	35	38	37	100	63	M30×1.5	32	15	1	8	4	53	8	58 000	147 000	18 000

1) The tolerance of outer ring outside diameter *D* of KRV···XH type and KRV···XLLH type having a cylindrical outside diameter surface is JIS Class 0.

Needle Roller Bearings

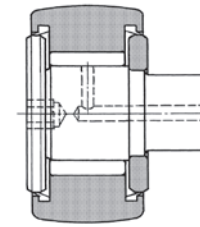

KRV···LLH type (Full complement roller sealed type)

Accessories

Applied bearing number	Grease nipple number	Plug number	Applied hexagonal nut
10 to 19	—	—	1M 3×0.5 to 1M 8×1.25
22 to 26	NIP-B4	SEN4	1M10×1.25
30 to 40	NIP-B6	SEN3, SEN6	1M12×1.5 to 1M18×1.5
47 to 90	NIP-B8	SEN4, SEN8	1M20×1.5 to 1M30×1.5



Grease fitting

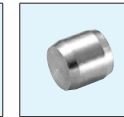

Plug

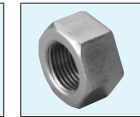

Hexagon nut

Track load capacity N	Allowable speed ²⁾ min ⁻¹	Maximum tightening torque N·m	Number				Mass kg (approx.)	Stud dia. mm		
			Spherical outer ring	Cylindrical outer ring	Spherical outer ring	Cylindrical outer ring				
560	1 360	*25 000	*32 000	0.5	KRV10H/3AS	KRV10XH/3AS	KRV10LLH/3AS	KRV10XLLH/3AS	0.005	3
725	1 790	*20 000	*27 000	1	KRV12H/3AS	KRV12XH/3AS	KRV12LLH/3AS	KRV12XLLH/3AS	0.008	4
805	2 220	*17 000	*22 000	2	KRV13H/3AS	KRV13XH/3AS	KRV13LLH/3AS	KRV13XLLH/3AS	0.011	5
1 080	3 400	*13 000	*16 000	3	KRV16FDOH/L588	KRV16FXDOH/L588	KRV16FLDOH/L588	KRV16FXLDOH/L588	0.020	6
1 380	4 050	10 000	*13 000	8	KRV19FDOH/L588	KRV19FXDOH/L588	KRV19FLDOH/L588	KRV19FXLDOH/L588	0.032	8
1 690	5 150	8 500	*11 000	14	KRV22FH/3AS	KRV22FXH/3AS	KRV22FLLH/3AS	KRV22FXLLH/3AS	0.047	10
2 120	6 100	8 500	*11 000	14	KRV26FH/3AS	KRV26FXH/3AS	KRV26FLLH/3AS	KRV26FXLLH/3AS	0.061	10
2 620	7 700	6 500	8 500	20	KRV30H/3AS	KRV30XH/3AS	KRV30LLH/3AS	KRV30XLLH/3AS	0.089	12
2 860	8 200	6 500	8 500	20	KRV32H/3AS	KRV32XH/3AS	KRV32LLH/3AS	KRV32XLLH/3AS	0.100	12
3 200	11 900	5 500	7 000	52	KRV35H/3AS	KRV35XH/3AS	KRV35LLH/3AS	KRV35XLLH/3AS	0.172	16
3 850	14 500	4 500	6 000	76	KRV40H/3AS	KRV40XH/3AS	KRV40LLH/3AS	KRV40XLLH/3AS	0.252	18
4 700	21 000	4 000	5 000	98	KRV47H/3AS	KRV47XH/3AS	KRV47LLH/3AS	KRV47XLLH/3AS	0.392	20
5 550	23 300	4 000	5 000	98	KRV52H/3AS	KRV52XH/3AS	KRV52LLH/3AS	KRV52XLLH/3AS	0.465	20
6 950	34 500	3 300	4 500	178	KRV62H/3AS	KRV62XH/3AS	KRV62LLH/3AS	KRV62XLLH/3AS	0.800	24
8 050	38 500	3 300	4 500	178	KRV72H/3AS	KRV72XH/3AS	KRV72LLH/3AS	KRV72XLLH/3AS	1.05	24
9 800	53 000	2 600	3 500	360	KRV80H/3AS	KRV80XH/3AS	KRV80LLH/3AS	KRV80XLLH/3AS	1.56	30
11 400	59 000	2 600	3 500	360	KRV90H/3AS	KRV90XH/3AS	KRV90LLH/3AS	KRV90XLLH/3AS	1.97	30

2) The allowable speed of KRV···LLH type and KRV···XLLH type with a "*" mark seal is about 10 000 min⁻¹.

Needle Roller Bearings



Cam follower stud type track roller metric series

- KRV type
- KRV··X type
- KRV··LL type
- KRV··XLL type

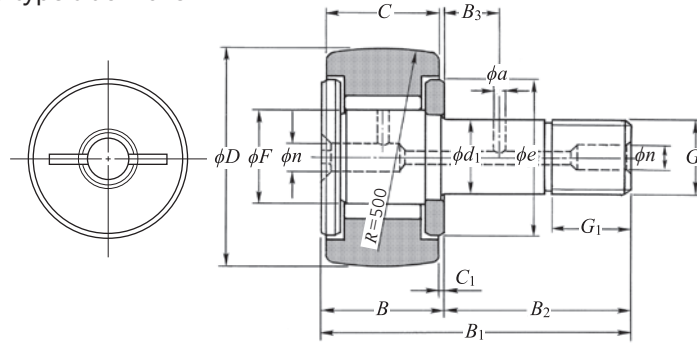

KRV type
(Full complement roller type)

D 16-90 mm

Outside dia. ¹⁾ mm D 0 -0.05	Dimensions mm													Basic load rating		Fatigue load limit N Cu
	d ₁	C	F	B	B ₁	B ₂	G	G ₁	B ₃	C ₁	n	a	e	C _r	C _{0r}	
16	6 ⁰ _{-0.012}	11	8	12	28	16	M 6×1	8	—	0.6	4 ²⁾	—	12	6 500	9 350	1 140
19	8 ⁰ _{-0.015}	11	10	12	32	20	M 8×1.25	10	—	0.6	4 ²⁾	—	14	7 450	11 700	1 430
22	10 ⁰ _{-0.015}	12	12	13	36	23	M10×1.25	12	—	0.6	4	—	17	8 200	14 000	1 700
26	10 ⁰ _{-0.015}	12	12	13	36	23	M10×1.25	12	—	0.6	4	—	17	8 200	14 000	1 700
30	12 ⁰ _{-0.018}	14	15	15	40	25	M12×1.5	13	6	0.6	6	3	23	12 000	20 300	2 470
32	12 ⁰ _{-0.018}	14	15	15	40	25	M12×1.5	13	6	0.6	6	3	23	12 000	20 300	2 470
35	16 ⁰ _{-0.018}	18	18	19.5	52	32.5	M16×1.5	17	8	0.8	6	3	27	17 600	34 000	4 150
40	18 ⁰ _{-0.018}	20	22	21.5	58	36.5	M18×1.5	19	8	0.8	6	3	32	19 400	42 000	5 100
47	20 ⁰ _{-0.021}	24	25	25.5	66	40.5	M20×1.5	21	9	0.8	8	4	37	28 800	61 000	7 450
52	20 ⁰ _{-0.021}	24	25	25.5	66	40.5	M20×1.5	21	9	0.8	8	4	37	28 800	61 000	7 450
62	24 ⁰ _{-0.021}	29	30	30.5	80	49.5	M24×1.5	25	11	0.8	8	4	44	39 500	98 500	12 000
72	24 ⁰ _{-0.021}	29	30	30.5	80	49.5	M24×1.5	25	11	0.8	8	4	44	39 500	98 500	12 000
80	30 ⁰ _{-0.021}	35	38	37	100	63	M30×1.5	32	15	1	8	4	53	58 000	147 000	18 000
90	30 ⁰ _{-0.021}	35	38	37	100	63	M30×1.5	32	15	1	8	4	53	58 000	147 000	18 000

Needle Roller Bearings

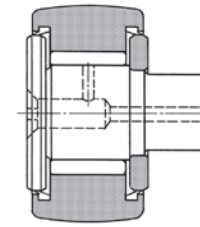

KRV··LL type
(Full complement roller sealed type)

Accessories

Applied bearing number	Grease nipple number	Plug number	Applied hexagonal nut
16 to 26	NIP-B4	SEN4	1M 6×1 to 1M10×1.25
30 to 40	NIP-B6	SEN3, SEN6	1M12×1.5 to 1M18×1.5
47 to 90	NIP-B8	SEN4, SEN8	1M20×1.5 to 1M30×1.5



Grease fitting



Plug



Hexagon nut

Track load capacity		Allowable speed ³⁾		Maximum tightening torque N·m	Number				Mass kg (approx.)	Stud dia. mm	
N	min ⁻¹	Grease lubrication	Oil lubrication		Without seal	With seal	Without seal	With seal			
Spherical outer ring	Cylindrical outer ring					Spherical outer ring	Cylindrical outer ring	Spherical outer ring	Cylindrical outer ring		
1 080	3 400	*13 000	*16 000	3		KRV16F/3AS	KRV16FX/3AS	KRV16FLL/3AS	KRV16FXLL/3AS	0.020	6
1 380	4 050	10 000	*13 000	8		KRV19F/3AS	KRV19FX/3AS	KRV19FLL/3AS	KRV19FXLL/3AS	0.032	8
1 690	5 150	8 500	*11 000	14		KRV22F/3AS	KRV22FX/3AS	KRV22FLL/3AS	KRV22FXLL/3AS	0.047	10
2 120	6 100	8 500	*11 000	14		KRV26F/3AS	KRV26FX/3AS	KRV26FLL/3AS	KRV26FXLL/3AS	0.061	10
2 620	7 700	6 500	8 500	20		KRV30/3AS	KRV30X/3AS	KRV30LL/3AS	KRV30XLL/3AS	0.089	12
2 860	8 200	6 500	8 500	20		KRV32/3AS	KRV32X/3AS	KRV32LL/3AS	KRV32XLL/3AS	0.100	12
3 200	11 900	5 500	7 000	52		KRV35/3AS	KRV35X/3AS	KRV35LL/3AS	KRV35XLL/3AS	0.172	16
3 850	14 500	4 500	6 000	76		KRV40/3AS	KRV40X/3AS	KRV40LL/3AS	KRV40XLL/3AS	0.252	18
4 700	21 000	4 000	5 000	98		KRV47/3AS	KRV47X/3AS	KRV47LL/3AS	KRV47XLL/3AS	0.390	20
5 550	23 300	4 000	5 000	98		KRV52/3AS	KRV52X/3AS	KRV52LL/3AS	KRV52XLL/3AS	0.465	20
6 950	34 500	3 300	4 500	178		KRV62/3AS	KRV62X/3AS	KRV62LL/3AS	KRV62XLL/3AS	0.800	24
8 050	38 500	3 300	4 500	178		KRV72/3AS	KRV72X/3AS	KRV72LL/3AS	KRV72XLL/3AS	1.05	24
9 800	53 000	2 600	3 500	360		KRV80/3AS	KRV80X/3AS	KRV80LL/3AS	KRV80XLL/3AS	1.56	30
11 400	59 000	2 600	3 500	360		KRV90/3AS	KRV90X/3AS	KRV90LL/3AS	KRV90XLL/3AS	1.97	30

1) The tolerance of outer ring outside diameter *D* of KRV··X type and KRV··XLL type having a cylindrical outside diameter surface is JIS Class 0.

2) A grease filler hole is provided only on the front surface (left side in the above drawing).

3) The allowable speed of KRV··LL type and KRV··XLL type with a "*" mark seal is about 10 000 min⁻¹.

Needle Roller Bearings



Cam follower stud type track roller metric series

KRT type
KRT··X type
KRT··LL type
KRT··XLL type

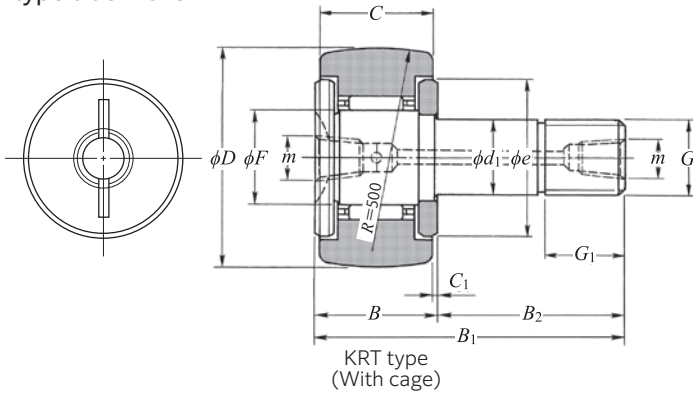

D 16–90 mm

Outside dia. ¹⁾ mm D 0 -0.05	Dimensions mm											Basic load rating		Fatigue load limit N Cu
	d ₁	C	F	B	B ₁	B ₂	G	G ₁	C ₁	m	e	C _r	C _{0r}	
16	6 ⁰ _{-0.012}	11	8	12	28	16	M 6×1	8	0.6	M4×0.7 ²⁾	12	4 050	4 200	510
19	8 ⁰ _{-0.015}	11	10	12	32	20	M 8×1.25	10	0.6	M4×0.7 ²⁾	14	4 750	5 400	660
22	10 ⁰ _{-0.015}	12	12	13	36	23	M10×1.25	12	0.6	M4×0.7	17	5 300	6 650	810
26	10 ⁰ _{-0.015}	12	12	13	36	23	M10×1.25	12	0.6	M4×0.7	17	5 300	6 650	810
30	12 ⁰ _{-0.018}	14	15	15	40	25	M12×1.5	13	0.6	M6×0.75	23	7 850	9 650	1 180
32	12 ⁰ _{-0.018}	14	15	15	40	25	M12×1.5	13	0.6	M6×0.75	23	7 850	9 650	1 180
35	16 ⁰ _{-0.018}	18	18	19.5	52	32.5	M16×1.5	17	0.8	Rc ½	27	12 200	17 900	2 180
40	18 ⁰ _{-0.018}	20	22	21.5	58	36.5	M18×1.5	19	0.8	Rc ½	32	14 000	22 800	2 785
47	20 ⁰ _{-0.021}	24	25	25.5	66	40.5	M20×1.5	21	0.8	Rc ½	37	20 700	33 500	4 100
52	20 ⁰ _{-0.021}	24	25	25.5	66	40.5	M20×1.5	21	0.8	Rc ½	37	20 700	33 500	4 100
62	24 ⁰ _{-0.021}	29	30	30.5	80	49.5	M24×1.5	25	0.8	Rc ½	44	28 900	55 000	6 700
72	24 ⁰ _{-0.021}	29	30	30.5	80	49.5	M24×1.5	25	0.8	Rc ½	44	28 900	55 000	6 700
80	30 ⁰ _{-0.021}	35	38	37	100	63	M30×1.5	32	1	Rc ½	53	45 000	88 500	10 800
85	30 ⁰ _{-0.021}	35	38	37	100	63	M30×1.5	32	1	Rc ½	53	45 000	88 500	10 800
90	30 ⁰ _{-0.021}	35	38	37	100	63	M30×1.5	32	1	Rc ½	53	45 000	88 500	10 800

1) The tolerance of outer ring outside diameter *D* of KRT··X type and KRT··XLL type having a cylindrical outside diameter surface is JIS Class 0.
2) A tapped hole is provided only on the front surface (left side in the above drawing).

Needle Roller Bearings

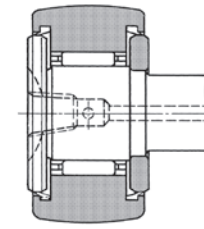

KRT··LL type
(Seal type with cage)

Accessories

Applied bearing number	Grease nipple number	Hex socket screw plug number	Applied hexagonal nut
16 to 26	NIP-X30	M4×0.7 ×4 ℓ	1M 6×1 to 1M10×1.25
30 to 32	JIS 1 type (A-M6F)	M6×0.75×6 ℓ	1M12×1.5
35 to 90	JIS 2 type (A-PT½)	R½(P1½)×7 ℓ	1M16×1.5 to 1M30×1.5

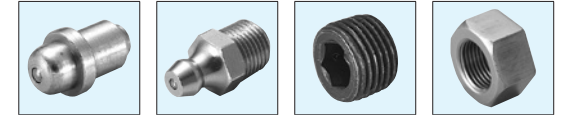

Grease fitting Grease fitting Hex socket screw plug Hexagon nut

Track load capacity		Allowable speed ³⁾		Maximum tightening torque N·m	Number				Mass kg (approx.)	Stud dia. mm
Spherical outer ring	Cylindrical outer ring	Grease lubrication	Oil lubrication		Without seal Spherical outer ring	Without seal Cylindrical outer ring	With seal Spherical outer ring	With seal Cylindrical outer ring		
1 080	3 400	*19 000	*25 000	3	KRT16	KRT16X	KRT16LL/3AS	KRT16XLL/3AS	0.019	6
1 380	4 050	*15 000	*20 000	8	KRT19	KRT19X	KRT19LL/3AS	KRT19XLL/3AS	0.031	8
1 690	5 150	*12 000	*16 000	14	KRT22	KRT22X	KRT22LL/3AS	KRT22XLL/3AS	0.046	10
2 120	6 100	*12 000	*16 000	14	KRT26	KRT26X	KRT26LL/3AS	KRT26XLL/3AS	0.059	10
2 620	7 700	10 000	*13 000	20	KRT30	KRT30X	KRT30LL/3AS	KRT30XLL/3AS	0.087	12
2 860	8 200	10 000	*13 000	20	KRT32	KRT32X	KRT32LL/3AS	KRT32XLL/3AS	0.097	12
3 200	11 900	8 000	*11 000	52	KRT35	KRT35X	KRT35LL/3AS	KRT35XLL/3AS	0.169	16
3 850	14 500	7 000	9 000	76	KRT40	KRT40X	KRT40LL/3AS	KRT40XLL/3AS	0.248	18
4 700	21 000	6 000	8 000	98	KRT47	KRT47X	KRT47LL/3AS	KRT47XLL/3AS	0.386	20
5 550	23 300	6 000	8 000	98	KRT52	KRT52X	KRT52LL/3AS	KRT52XLL/3AS	0.461	20
6 950	34 500	5 000	6 500	178	KRT62	KRT62X	KRT62LL/3AS	KRT62XLL/3AS	0.790	24
8 050	38 500	5 000	6 500	178	KRT72	KRT72X	KRT72LL/3AS	KRT72XLL/3AS	1.04	24
9 800	53 000	4 000	5 500	360	KRT80	KRT80X	KRT80LL/3AS	KRT80XLL/3AS	1.55	30
10 400	56 000	4 000	5 500	360	KRT85	KRT85X	KRT85LL/3AS	KRT85XLL/3AS	1.74	30
11 400	59 000	4 000	5 500	360	KRT90	KRT90X	KRT90LL/3AS	KRT90XLL/3AS	1.95	30

3) The allowable speed of KRT··LL type and KRT··XLL type with a “*” mark seal is about 10 000 min⁻¹.

Needle Roller Bearings



Cam follower stud type track roller metric series

KRVT type
KRVT··X type
KRVT··LL type
KRVT··XLL type

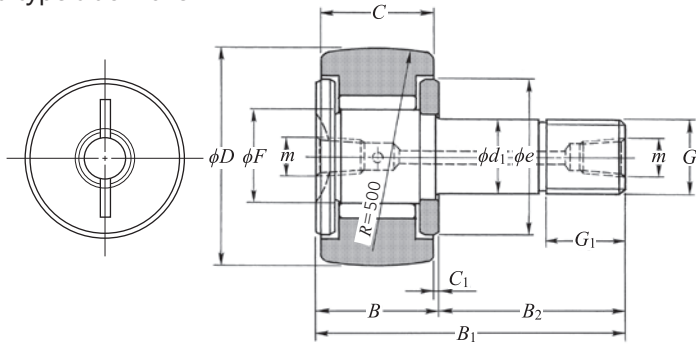

KRVT type
(Full complement roller type)

D 16–90 mm

Outside dia. ¹⁾ mm D 0 -0.05	Dimensions mm											Basic load rating		Fatigue load limit N Cu
	d ₁	C	F	B	B ₁	B ₂	G	G ₁	C ₁	m	e	C _r	C _{0r}	
16	6 ⁰ _{-0.012}	11	8	12	28	16	M 6×1	8	0.6	M4×0.7 ²⁾	12	6 500	9 350	1 140
19	8 ⁰ _{-0.015}	11	10	12	32	20	M 8×1.25	10	0.6	M4×0.7 ²⁾	14	7 450	11 700	1 430
22	10 ⁰ _{-0.015}	12	12	13	36	23	M10×1.25	12	0.6	M4×0.7	17	8 200	14 000	1 700
26	10 ⁰ _{-0.015}	12	12	13	36	23	M10×1.25	12	0.6	M4×0.7	17	8 200	14 000	1 700
30	12 ⁰ _{-0.018}	14	15	15	40	25	M12×1.5	13	0.6	M6×0.75	23	12 000	20 300	2 470
32	12 ⁰ _{-0.018}	14	15	15	40	25	M12×1.5	13	0.6	M6×0.75	23	12 000	20 300	2 470
35	16 ⁰ _{-0.018}	18	18	19.5	52	32.5	M16×1.5	17	0.8	Rc ½	27	17 600	34 000	4 150
40	18 ⁰ _{-0.018}	20	22	21.5	58	36.5	M18×1.5	19	0.8	Rc ½	32	19 400	42 000	5 100
47	20 ⁰ _{-0.021}	24	25	25.5	66	40.5	M20×1.5	21	0.8	Rc ½	37	28 800	61 000	7 450
52	20 ⁰ _{-0.021}	24	25	25.5	66	40.5	M20×1.5	21	0.8	Rc ½	37	28 800	61 000	7 450
62	24 ⁰ _{-0.021}	29	30	30.5	80	49.5	M24×1.5	25	0.8	Rc ½	44	39 500	98 500	12 000
72	24 ⁰ _{-0.021}	29	30	30.5	80	49.5	M24×1.5	25	0.8	Rc ½	44	39 500	98 500	12 000
80	30 ⁰ _{-0.021}	35	38	37	100	63	M30×1.5	32	1	Rc ½	53	58 000	147 000	18 000
90	30 ⁰ _{-0.021}	35	38	37	100	63	M30×1.5	32	1	Rc ½	53	58 000	147 000	18 000

1) The tolerance of outer ring outside diameter D of KRVT··X type and KRVT··XLL type having a cylindrical outside diameter surface is JIS Class 0.
2) A tapped hole is provided only on the front surface (left side in the above drawing).

Needle Roller Bearings

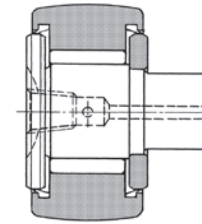

KRVT··LL type
(Full complement roller sealed type)

Accessories

Applied bearing number	Grease nipple number	Hex socket screw plug number	Applied hexagonal nut
16 to 26	NIP-X30	M4×0.7 ×4 ℓ	1M 6×1 to 1M10×1.25
30 to 32	JIS 1 type (A-M6F)	M6×0.75×6 ℓ	1M12×1.5
35 to 90	JIS 2 type (A-PT½)	R½(PT½)×7 ℓ	1M16×1.5 to 1M30×1.5

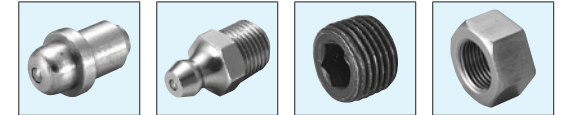

Grease fitting Grease fitting Hex socket screw plug Hexagon nut

Track load capacity		Allowable speed ³⁾		Maximum tightening torque N·m	Number				Mass kg (approx.)	Stud dia. mm
Spherical outer ring	Cylindrical outer ring	Grease lubrication	Oil lubrication		Without seal Spherical outer ring	Without seal Cylindrical outer ring	With seal Spherical outer ring	With seal Cylindrical outer ring		
1 080	3 400	*13 000	*16 000	3	KRVT16/3AS	KRVT16X/3AS	KRVT16LL/3AS	KRVT16XLL/3AS	0.020	6
1 380	4 050	10 000	*13 000	8	KRVT19/3AS	KRVT19X/3AS	KRVT19LL/3AS	KRVT19XLL/3AS	0.032	8
1 690	5 150	8 500	*11 000	14	KRVT22/3AS	KRVT22X/3AS	KRVT22LL/3AS	KRVT22XLL/3AS	0.047	10
2 120	6 100	8 500	*11 000	14	KRVT26/3AS	KRVT26X/3AS	KRVT26LL/3AS	KRVT26XLL/3AS	0.061	10
2 620	7 700	6 500	8 500	20	KRVT30/3AS	KRVT30X/3AS	KRVT30LL/3AS	KRVT30XLL/3AS	0.089	12
2 860	8 200	6 500	8 500	20	KRVT32/3AS	KRVT32X/3AS	KRVT32LL/3AS	KRVT32XLL/3AS	0.100	12
3 200	11 900	5 500	7 000	52	KRVT35/3AS	KRVT35X/3AS	KRVT35LL/3AS	KRVT35XLL/3AS	0.172	16
3 850	14 500	4 500	6 000	76	KRVT40/3AS	KRVT40X/3AS	KRVT40LL/3AS	KRVT40XLL/3AS	0.252	18
4 700	21 000	4 000	5 000	98	KRVT47/3AS	KRVT47X/3AS	KRVT47LL/3AS	KRVT47XLL/3AS	0.390	20
5 550	23 300	4 000	5 000	98	KRVT52/3AS	KRVT52X/3AS	KRVT52LL/3AS	KRVT52XLL/3AS	0.465	20
6 950	34 500	3 300	4 500	178	KRVT62/3AS	KRVT62X/3AS	KRVT62LL/3AS	KRVT62XLL/3AS	0.800	24
8 050	38 500	3 300	4 500	178	KRVT72/3AS	KRVT72X/3AS	KRVT72LL/3AS	KRVT72XLL/3AS	1.05	24
9 800	53 000	2 600	3 500	360	KRVT80/3AS	KRVT80X/3AS	KRVT80LL/3AS	KRVT80XLL/3AS	1.56	30
11 400	59 000	2 600	3 500	360	KRVT90/3AS	KRVT90X/3AS	KRVT90LL/3AS	KRVT90XLL/3AS	1.97	30

3) The allowable speed of KRVT··LL type and KRVT··XLL type with a "*" mark seal is about 10 000 min⁻¹.

Needle Roller Bearings



Cam follower stud type track roller
metric series

NUKR··H type
NUKR··XH type

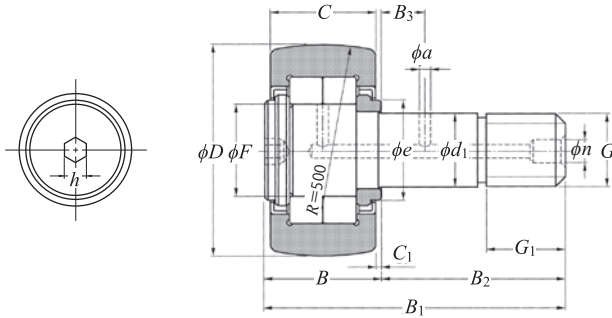

NUKR··H type ($D < 100$ mm)
(Full complement double-row cylindrical roller bearings with shield)

D 30–180 mm

Outside dia. ¹⁾ mm D 0 -0.05	Dimensions														Fatigue load limit N C_u		
	d_1	C	F	B	B_1	B_2	G	G_1	B_3	C_1	n	m	a	e		h	
30	12	0	14	14.5	15	40	25	M12×1.5	13	6	0.6	6	—	3	15	6	1 650
35	16	0	18	19	19.5	52	32.5	M16×1.5	17	8	0.8	6	—	3	21	6	3 150
40	18	0	20	21.5	21.5	58	36.5	M18×1.5	19	8	0.8	6	—	3	23	6	3 550
47	20	0	24	25.5	25.5	66	40.5	M20×1.5	21	9	0.8	8	—	4	27	8	5 900
52	20	0	24	30	25.5	66	40.5	M20×1.5	21	9	0.8	8	—	4	31	8	7 000
62	24	0	29	35	30.5	80	49.5	M24×1.5	25	11	0.8	8	—	4	38	8	8 850
72	24	0	29	41.5	30.5	80	49.5	M24×1.5	25	11	0.8	8	—	4	44	8	10 400
80	30	0	35	47.5	37	100	63	M30×1.5	32	15	1	8	—	4	51	8	18 400
90	30	0	35	47.5	37	100	63	M30×1.5	32	15	1	8	—	4	51	8	18 400
100	36	0	43	48.5	46	120	74	M36×1.5	38	—	1.5	—	Rc 1/8	—	53	14	20 400
120	42	0	50	60.5	53	140	87	M42×1.5	44	—	1.5	—	Rc 1/8	—	66	14	32 400
140	48	0	57	65	60	160	100	M48×1.5	52	—	1.5	—	Rc 1/8	—	72.5	14	35 900
150	52	0	60	75.5	63	170	107	M52×1.5	52	—	1.5	—	Rc 1/8	—	85.5	17	46 500
160	56	0	63	80.5	67	180	113	M56×3	58	—	2	—	Rc 1/8	—	89.5	17	49 000
170	60	0	66	86	70	190	120	M60×3	58	—	2	—	Rc 1/8	—	96.5	17	58 000
180	64	0	72	91.5	76	200	124	M64×3	65	—	2	—	Rc 1/8	—	103.5	17	67 500

1) The tolerance of outer ring outside diameter D of NUKR··XH type having a cylindrical outside diameter surface is JIS Class 0.

Needle Roller Bearings

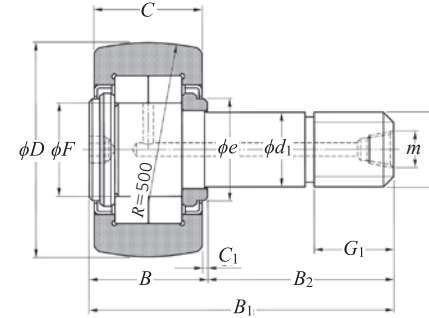

NUKR··H type ($D \geq 100$ mm)

Accessories

Applied bearing number	Grease nipple number	Plug number	Applied hexagonal nut
30 to 40	NIP-B6	SEN3, SEN6	1M12×1.5 to 1M18×1.5
47 to 90	NIP-B8	SEN4, SEN8	1M20×1.5 to 1M30×1.5
100 to 180	JIS 2 type (A-PT1/8)	—	1M36×1.5 to 1M64×3

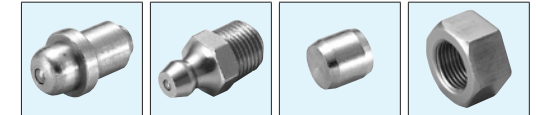

Grease fitting Grease fitting Plug Hexagon nut

Basic load rating		Track load capacity		Allowable speed min^{-1} Grease lubrication	Maximum tightening torque N·m	Number		Mass kg (approx.)	Stud dia. mm
dynamic N C_r	static N C_{0r}	Spherical outer ring	Cylindrical outer ring			Spherical outer ring	Cylindrical outer ring		
13 300	13 500	2 620	7 700	6 900	20	NUKR30H/3AS	NUKR30XH/3AS	0.088	12
22 300	25 700	3 200	11 900	5 500	52	NUKR35H/3AS	NUKR35XH/3AS	0.165	16
24 100	29 100	3 850	14 500	4 700	76	NUKR40H/3AS	NUKR40XH/3AS	0.242	18
38 500	48 000	4 700	21 000	4 000	98	NUKR47H/3AS	NUKR47XH/3AS	0.380	20
42 500	57 500	5 550	23 300	3 300	98	NUKR52H/3AS	NUKR52XH/3AS	0.450	20
56 500	72 500	6 950	34 500	2 900	178	NUKR62H/3AS	NUKR62XH/3AS	0.795	24
62 000	85 500	8 050	38 500	2 400	178	NUKR72H/3AS	NUKR72XH/3AS	1.01	24
101 000	151 000	9 800	53 000	2 100	360	NUKR80H/3AS	NUKR80XH/3AS	1.54	30
101 000	151 000	11 400	59 000	2 100	360	NUKR90H/3AS	NUKR90XH/3AS	1.96	30
119 000	167 000	13 000	79 000	2 000	630	NUKR100H/3AS	NUKR100XH/3AS	3.08	36
172 000	266 000	16 400	113 000	1 700	1 020	NUKR120H/3AS	NUKR120XH/3AS	5.17	42
201 000	294 000	20 000	152 000	1 500	1 540	NUKR140H/3AS	NUKR140XH/3AS	7.98	48
258 000	380 000	22 000	173 000	1 300	1 950	NUKR150H/3AS	NUKR150XH/3AS	9.70	52
274 000	400 000	24 000	194 000	1 200	2 480	NUKR160H/3AS	NUKR160XH/3AS	11.7	56
320 000	475 000	26 000	218 000	1 100	3 030	NUKR170H/3AS	NUKR170XH/3AS	13.9	60
365 000	555 000	27 900	253 000	1 000	3 670	NUKR180H/3AS	NUKR180XH/3AS	17.0	64

Needle Roller Bearings



Cam follower stud type track roller metric series

NUKR type
NUKR··X type

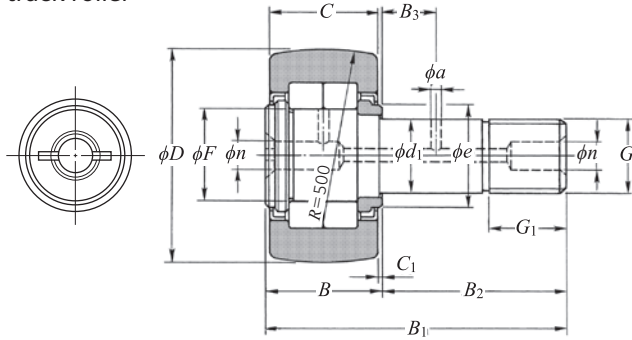

NUKR type ($D < 100$ mm)
(Full complement double-row cylindrical roller bearings with shield)

D 30–180 mm

Outside dia. ¹⁾ mm D 0 -0.05	Dimensions														Fatigue load limit N C_u	
	mm															
	d_1	C	F	B	B_1	B_2	G	G_1	B_3	C_1	n	m	a	e		
30	12	0	14	14.5	15	40	25	M12×1.5	13	6	0.6	6	—	3	15	1 650
35	16	0	18	19	19.5	52	32.5	M16×1.5	17	8	0.8	6	—	3	21	3 150
40	18	0	20	21.5	21.5	58	36.5	M18×1.5	19	8	0.8	6	—	3	23	3 550
47	20	0	24	25.5	25.5	66	40.5	M20×1.5	21	9	0.8	8	—	4	27	5 900
52	20	0	24	30	25.5	66	40.5	M20×1.5	21	9	0.8	8	—	4	31	7 000
62	24	0	29	35	30.5	80	49.5	M24×1.5	25	11	0.8	8	—	4	38	8 850
72	24	0	29	41.5	30.5	80	49.5	M24×1.5	25	11	0.8	8	—	4	44	10 400
80	30	0	35	47.5	37	100	63	M30×1.5	32	15	1	8	—	4	51	18 400
90	30	0	35	47.5	37	100	63	M30×1.5	32	15	1	8	—	4	51	18 400
100	36	0	43	48.5	46	120	74	M36×1.5	38	—	1.5	8	Rc 1/8	—	53	20 400
120	42	0	50	60.5	53	140	87	M42×1.5	44	—	1.5	8	Rc 1/8	—	66	32 500
140	48	0	57	65	60	160	100	M48×1.5	52	—	1.5	8	Rc 1/8	—	72.5	36 000
150	52	0	60	75.5	63	170	107	M52×1.5	52	—	1.5	8	Rc 1/8	—	85.5	46 500
160	56	0	63	80.5	67	180	113	M56×3	58	—	2	8	Rc 1/8	—	89.5	49 000
170	60	0	66	86	70	190	120	M60×3	58	—	2	8	Rc 1/8	—	96.5	58 000
180	64	0	72	91.5	76	200	124	M64×3	65	—	2	8	Rc 1/8	—	103.5	67 500

1) The tolerance of outer ring outside diameter D of NUKR··X type having a cylindrical outside diameter surface is JIS Class 0.

Needle Roller Bearings

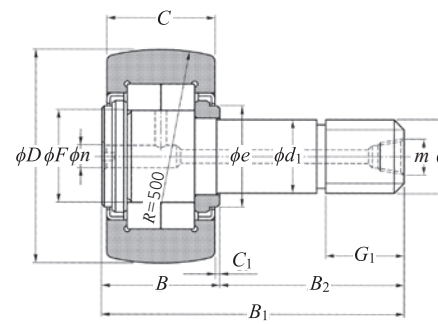

NUKR type ($D \geq 100$ mm)

Accessories

Applied bearing number	Grease nipple number	Plug number	Applied hexagonal nut
30 to 40	NIP-B6	SEN3, SEN6	1M12×1.5 to 1M18×1.5
47 to 90	NIP-B8	SEN4, SEN8	1M20×1.5 to 1M30×1.5
100 to 180	JIS 2 type (A-PT1/8)	—	1M36×1.5 to 1M64×3



Grease fitting

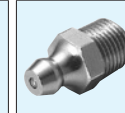

Grease fitting



Plug



Hexagon nut

Basic load rating	Track load capacity	Allowable speed	Maximum tightening torque	Number		Mass	Stud dia.		
				Spherical outer ring	Cylindrical outer ring				
dynamic N C_r	static N C_{0r}	min^{-1} Grease lubrication	N·m			kg (approx.)	mm		
13 300	13 500	2 620	7 700	6 900	20	NUKR 30/3AS	NUKR 30X/3AS	0.088	12
22 300	25 700	3 200	11 900	5 500	52	NUKR 35/3AS	NUKR 35X/3AS	0.165	16
24 100	29 100	3 850	14 500	4 700	76	NUKR 40/3AS	NUKR 40X/3AS	0.242	18
38 500	48 000	4 700	21 000	4 000	98	NUKR 47/3AS	NUKR 47X/3AS	0.380	20
42 500	57 500	5 550	23 300	3 300	98	NUKR 52/3AS	NUKR 52X/3AS	0.450	20
56 500	72 500	6 950	34 500	2 900	178	NUKR 62/3AS	NUKR 62X/3AS	0.795	24
62 000	85 500	8 050	38 500	2 400	178	NUKR 72/3AS	NUKR 72X/3AS	1.01	24
101 000	151 000	9 800	53 000	2 100	360	NUKR 80/3AS	NUKR 80X/3AS	1.54	30
101 000	151 000	11 400	59 000	2 100	360	NUKR 90/3AS	NUKR 90X/3AS	1.96	30
119 000	167 000	13 000	79 000	2 000	630	NUKR 100/3AS	NUKR 100X/3AS	3.08	36
172 000	266 000	16 400	113 000	1 700	1 020	NUKR 120/3AS	NUKR 120X/3AS	5.17	42
201 000	294 000	20 000	152 000	1 500	1 540	NUKR 140/3AS	NUKR 140X/3AS	7.98	48
258 000	380 000	22 000	173 000	1 300	1 950	NUKR 150/3AS	NUKR 150X/3AS	9.70	52
274 000	400 000	24 000	194 000	1 200	2 480	NUKR 160/3AS	NUKR 160X/3AS	11.7	56
320 000	475 000	26 000	218 000	1 100	3 030	NUKR 170/3AS	NUKR 170X/3AS	13.9	60
365 000	555 000	27 900	253 000	1 000	3 670	NUKR 180/3AS	NUKR 180X/3AS	17.0	64

Needle Roller Bearings



Cam follower stud type track roller metric series

NUKRT type
NUKRT··X type

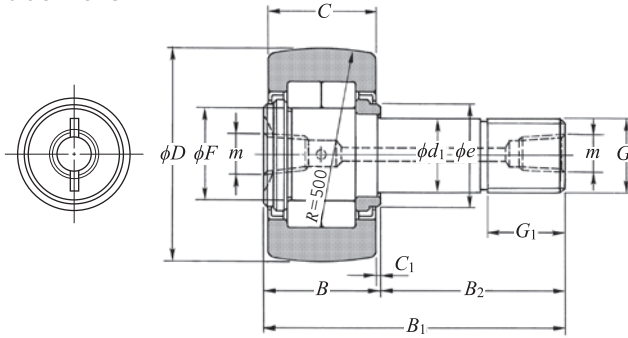

NUKRT type
(Full complement double-row cylindrical roller bearings with shield)

D 30–180 mm

Outside dia. ¹⁾ mm D 0 -0.05	Dimensions mm											Basic load rating		Fatigue load limit N C _u
	d ₁	C	F	B	B ₁	B ₂	G	G ₁	C ₁	m	e	C _r	C _{0r}	
30	12 ⁰ _{-0.018}	14	14.5	15	40	25	M12×1.5	13	0.6	M6×0.75	15	13 300	13 500	1 650
35	16 ⁰ _{-0.018}	18	19	19.5	52	32.5	M16×1.5	17	0.8	Rc ½	21	22 300	25 700	3 150
40	18 ⁰ _{-0.018}	20	21.5	21.5	58	36.5	M18×1.5	19	0.8	Rc ½	23	24 100	29 100	3 550
47	20 ⁰ _{-0.021}	24	25.5	25.5	66	40.5	M20×1.5	21	0.8	Rc ½	27	38 500	48 000	5 900
52	20 ⁰ _{-0.021}	24	30	25.5	66	40.5	M20×1.5	21	0.8	Rc ½	31	42 500	57 500	7 000
62	24 ⁰ _{-0.021}	29	35	30.5	80	49.5	M24×1.5	25	0.8	Rc ½	38	56 500	72 500	8 850
72	24 ⁰ _{-0.021}	29	41.5	30.5	80	49.5	M24×1.5	25	0.8	Rc ½	44	62 000	85 500	10 400
80	30 ⁰ _{-0.021}	35	47.5	37	100	63	M30×1.5	32	1	Rc ½	51	101 000	151 000	18 400
90	30 ⁰ _{-0.021}	35	47.5	37	100	63	M30×1.5	32	1	Rc ½	51	101 000	151 000	18 400
100	36 ⁰ _{-0.025}	43	48.5	46	120	74	M36×1.5	38	1.5	Rc ½	53	119 000	167 000	20 400
120	42 ⁰ _{-0.025}	50	60.5	53	140	87	M42×1.5	44	1.5	Rc ½	66	172 000	266 000	32 500
140	48 ⁰ _{-0.025}	57	65	60	160	100	M48×1.5	52	1.5	Rc ½	72.5	201 000	294 000	36 000
150	52 ⁰ _{-0.030}	60	75.5	63	170	107	M52×1.5	52	1.5	Rc ½	85.5	258 000	380 000	46 500
160	56 ⁰ _{-0.030}	63	80.5	67	180	113	M56×3	58	2	Rc ½	89.5	274 000	400 000	49 000
170	60 ⁰ _{-0.030}	66	86	70	190	120	M60×3	58	2	Rc ½	96.5	320 000	475 000	58 000
180	64 ⁰ _{-0.030}	72	91.5	76	200	124	M64×3	65	2	Rc ½	103.5	365 000	555 000	67 500

1) The tolerance of outer ring outside diameter D of NUKRT··X type having a cylindrical outside diameter surface is JIS Class 0.

Needle Roller Bearings



Accessories

Applied bearing number	Grease nipple number	Hex socket screw plug number	Applied hexagonal nut
30	JIS 1 type (A-M6F)	M6×0.75×6 ℓ	1M12×1.5
35 to 180	JIS 2 type (A-PT½)	R½(PT½)×7 ℓ	1M16×1.5 to 1M64×3



Grease fitting



Hex socket screw plug



Hexagon nut

Track load capacity		Allowable speed min ⁻¹ Grease lubrication	Maximum tightening torque N·m	Number		Mass kg (approx.)	Stud dia. mm
Spherical outer ring	Cylindrical outer ring			Spherical outer ring	Cylindrical outer ring		
2 620	7 700	6 900	20	NUKRT 30/3AS	NUKRT 30X/3AS	0.088	12
3 200	11 900	5 500	52	NUKRT 35/3AS	NUKRT 35X/3AS	0.165	16
3 850	14 500	4 700	76	NUKRT 40/3AS	NUKRT 40X/3AS	0.242	18
4 700	21 000	4 000	98	NUKRT 47/3AS	NUKRT 47X/3AS	0.380	20
5 550	23 300	3 300	98	NUKRT 52/3AS	NUKRT 52X/3AS	0.450	20
6 950	34 500	2 900	178	NUKRT 62/3AS	NUKRT 62X/3AS	0.795	24
8 050	38 500	2 400	178	NUKRT 72/3AS	NUKRT 72X/3AS	1.01	24
9 800	53 000	2 100	360	NUKRT 80/3AS	NUKRT 80X/3AS	1.54	30
11 400	59 000	2 100	360	NUKRT 90/3AS	NUKRT 90X/3AS	1.96	30
13 000	79 000	2 000	630	NUKRT 100/3AS	NUKRT 100X/3AS	3.08	36
16 400	113 000	1 700	1 020	NUKRT 120/3AS	NUKRT 120X/3AS	5.17	42
20 000	152 000	1 500	1 540	NUKRT 140/3AS	NUKRT 140X/3AS	7.98	48
22 000	173 000	1 300	1 950	NUKRT 150/3AS	NUKRT 150X/3AS	9.70	52
24 000	194 000	1 200	2 480	NUKRT 160/3AS	NUKRT 160X/3AS	11.7	56
26 000	218 000	1 100	3 030	NUKRT 170/3AS	NUKRT 170X/3AS	13.9	60
27 900	253 000	1 000	3 670	NUKRT 180/3AS	NUKRT 180X/3AS	17.0	64

Needle Roller Bearings

NTN

Roller follower yoke type track roller
metric series

NATR type
NATR··X type
NATR··LL type
NATR··XLL type

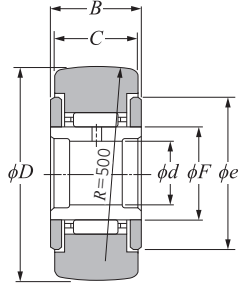

NATR type
(With cage)

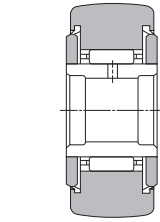

NATR··LL type
(Seal type with cage)

D 16–90 mm

Outside dia. ¹⁾ mm D $0_{-0.05}$	Dimensions					Basic load rating		Track load capacity		Fatigue load limit N C_u	
	mm					dynamic N C_r	static N C_{0r}	Spherical outer ring N	Cylindrical outer ring N		
	d	B	C	e	F						
16	5	12	$0_{-0.180}$	11	12	8	4 050	4 200	1 080	3 400	510
19	6	12	$0_{-0.180}$	11	14	10	4 750	5 400	1 380	4 050	660
24	8	15	$0_{-0.180}$	14	19	12	6 900	7 700	1 900	6 650	940
30	10	15	$0_{-0.180}$	14	23	15	7 850	9 650	2 620	7 700	1 180
32	12	15	$0_{-0.180}$	14	25	17	8 400	10 900	2 860	8 200	1 330
35	15	19	$0_{-0.210}$	18	27	20	13 300	20 800	3 200	11 900	2 530
40	17	21	$0_{-0.210}$	20	32	22	14 000	22 800	3 850	14 500	2 790
47	20	25	$0_{-0.210}$	24	37	25	20 700	33 500	4 700	21 000	4 100
52	25	25	$0_{-0.210}$	24	42	30	22 800	40 500	5 500	23 300	4 950
62	30	29	$0_{-0.210}$	28	51	38	36 000	66 000	6 950	33 000	8 100
72	35	29	$0_{-0.210}$	28	58	44.5	39 000	77 000	8 050	37 000	9 400
80	40	32	$0_{-0.250}$	30	66	50	49 500	92 500	9 800	44 500	11 300
85	45	32	$0_{-0.250}$	30	71	55	51 500	100 000	10 400	47 000	12 200
90	50	32	$0_{-0.250}$	30	76	60	53 000	108 000	11 400	50 000	13 200

1) The tolerance of outer ring outside diameter D of NATR··X type and NATR··XLL type having a cylindrical outside diameter surface is JIS Class 0.

Needle Roller Bearings

NTN

Allowable speed ²⁾		Number				Mass kg (approx.)	Outside dia. ¹⁾ mm D $0_{-0.05}$
min ⁻¹ Grease lubrication	Oil lubrication	Without seal Spherical outer ring	Cylindrical outer ring	With seal Spherical outer ring	Cylindrical outer ring		
*19 000	*25 000	NATR5	NATR5X	NATR5LL/3AS	NATR5XLL/3AS	0.018	16
*15 000	*20 000	NATR6	NATR6X	NATR6LL/3AS	NATR6XLL/3AS	0.025	19
*12 000	*16 000	NATR8	NATR8X	NATR8LL/3AS	NATR8XLL/3AS	0.042	24
10 000	*13 000	NATR10	NATR10X	NATR10LL/3AS	NATR10XLL/3AS	0.061	30
9 000	*12 000	NATR12CT	NATR12XCT	NATR12CLLT/3AS	NATR12CXLLT/3AS	0.069	32
7 500	10 000	NATR15	NATR15X	NATR15LL/3AS	NATR15XLL/3AS	0.098	35
7 000	9 000	NATR17	NATR17X	NATR17LL/3AS	NATR17XLL/3AS	0.140	40
6 000	8 000	NATR20	NATR20X	NATR20LL/3AS	NATR20XLL/3AS	0.246	47
5 000	6 500	NATR25	NATR25X	NATR25LL/3AS	NATR25XLL/3AS	0.275	52
4 000	5 500	NATR30	NATR30X	NATR30LL/3AS	NATR30XLL/3AS	0.470	62
3 300	4 500	NATR35	NATR35X	NATR35LL/3AS	NATR35XLL/3AS	0.635	72
3 000	4 000	NATR40	NATR40X	NATR40LL/3AS	NATR40XLL/3AS	0.875	80
2 700	3 600	NATR45	NATR45X	NATR45LL/3AS	NATR45XLL/3AS	0.910	85
2 500	3 300	NATR50	NATR50X	NATR50LL/3AS	NATR50XLL/3AS	0.960	90

2) The allowable speed of bearings with a "*" mark seal is about 10 000 min⁻¹.

Needle Roller Bearings

Roller follower yoke type track roller metric series

- NATV type
- NATV··X type
- NATV··LL type
- NATV··XLL type

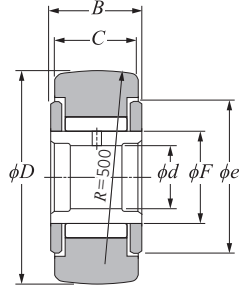

NATV type
(Full complement roller type)

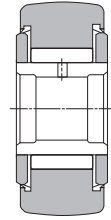

NATV··LL type
(Full complement roller sealed type)

D 16–90 mm

Outside dia. ¹⁾ mm D 0 -0.05	Dimensions					Basic load rating		Track load capacity		Fatigue load limit N C _u	
	mm					dynamic N C _r	static N C _{0r}	N			
	d	B	C	e	F			Spherical outer ring	Cylindrical outer ring		
16	5	12	0 -0.180	11	12	8	6 500	9 350	1 080	3 400	1 140
19	6	12	0 -0.180	11	14	10	7 450	11 700	1 380	4 050	1 430
24	8	15	0 -0.180	14	19	12	10 700	16 200	1 900	6 650	1 980
30	10	15	0 -0.180	14	23	15	12 000	20 300	2 620	7 700	2 470
32	12	15	0 -0.180	14	25	17	13 000	23 000	2 860	8 200	2 810
35	15	19	0 -0.210	18	27	20	18 400	38 000	3 200	11 900	4 650
40	17	21	0 -0.210	20	32	22	19 400	42 000	3 850	14 500	5 100
47	20	25	0 -0.210	24	37	25	28 800	61 000	4 700	21 000	7 450
52	25	25	0 -0.210	24	42	30	31 500	73 500	5 500	23 300	8 950
62	30	29	0 -0.210	28	51	38	47 500	115 000	6 950	33 000	14 000
72	35	29	0 -0.210	28	58	44.5	52 000	134 000	8 050	37 000	16 300
80	40	32	0 -0.250	30	66	50	68 500	171 000	9 800	44 500	20 900
90	50	32	0 -0.250	30	76	60	76 000	205 000	11 400	50 000	25 000

Needle Roller Bearings

Allowable speed ²⁾		Number				Mass kg (approx.)	Outside dia. ¹⁾ mm D 0 -0.05
Grease lubrication	Oil lubrication	Without seal Spherical outer ring	Cylindrical outer ring	With seal Spherical outer ring	Cylindrical outer ring		
*13 000	*16 000	NATV5/3AS	NATV5X/3AS	NATV5LL/3AS	NATV5XLL/3AS	0.020	16
10 000	*13 000	NATV6/3AS	NATV6X/3AS	NATV6LL/3AS	NATV6XLL/3AS	0.027	19
8 500	*11 000	NATV8/3AS	NATV8X/3AS	NATV8LL/3AS	NATV8XLL/3AS	0.044	24
6 500	8 500	NATV10/3AS	NATV10X/3AS	NATV10LL/3AS	NATV10XLL/3AS	0.065	30
6 000	7 500	NATV12/3AS	NATV12X/3AS	NATV12LL/3AS	NATV12XLL/3AS	0.074	32
5 000	6 500	NATV15/3AS	NATV15X/3AS	NATV15LL/3AS	NATV15XLL/3AS	0.102	35
4 500	6 000	NATV17/3AS	NATV17X/3AS	NATV17LL/3AS	NATV17XLL/3AS	0.145	40
4 000	5 000	NATV20/3AS	NATV20X/3AS	NATV20LL/3AS	NATV20XLL/3AS	0.254	47
3 300	4 500	NATV25/3AS	NATV25X/3AS	NATV25LL/3AS	NATV25XLL/3AS	0.285	52
2 600	3 500	NATV30/3AS	NATV30X/3AS	NATV30LL/3AS	NATV30XLL/3AS	0.481	62
2 200	2 900	NATV35/3AS	NATV35X/3AS	NATV35LL/3AS	NATV35XLL/3AS	0.647	72
2 000	2 600	NATV40/3AS	NATV40X/3AS	NATV40LL/3AS	NATV40XLL/3AS	0.890	80
1 600	2 100	NATV50/3AS	NATV50X/3AS	NATV50LL/3AS	NATV50XLL/3AS	0.990	90

1) The tolerance of outer ring outside diameter *D* of NATV··X type and NATV··XLL type having a cylindrical outside diameter surface is JIS Class 0.

2) The allowable speed of bearings with a "*" mark seal is about 10 000 min⁻¹.

Needle Roller Bearings

NTN

Roller follower yoke type track roller
metric series

NUTR2 type
NUTR2··X type
NUTR3 type
NUTR3··X type

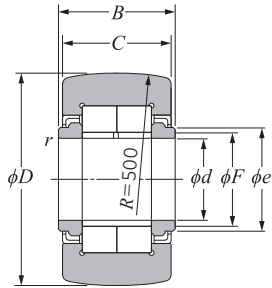

NUTR2 type
NUTR3 type

D 35–110 mm

Outside dia. ¹⁾ mm D 0 -0.05	Dimensions mm						Basic load rating		Track load capacity		Fatigue load limit N C_u	
	d	B	C	e	F	r_s min ²⁾	dynamic N C_r	static C_{0r}	Spherical outer ring N	Cylindrical outer ring N		
35	15	19	$0_{-0.210}$	18	20	19	0.3	22 300	25 700	3 200	11 900	3 150
40	17	21	$0_{-0.210}$	20	22	21.5	0.3	24 100	29 100	3 850	14 500	3 550
42	15	19	$0_{-0.210}$	18	20	19	0.3	22 300	25 700	4 100	14 300	3 150
47	17	21	$0_{-0.210}$	20	22	21.5	0.3	24 100	29 100	4 700	17 000	3 550
	20	25	$0_{-0.210}$	24	27	25.5	0.3	38 500	48 000	4 700	21 000	5 900
52	20	25	$0_{-0.210}$	24	27	25.5	0.3	38 500	48 000	5 550	23 300	5 900
	25	25	$0_{-0.210}$	24	31	30	0.3	42 500	57 500	5 550	23 300	7 000
62	25	25	$0_{-0.210}$	24	31	30	0.3	42 500	57 500	6 950	27 800	7 000
	30	29	$0_{-0.210}$	28	38	35	0.3	56 500	72 500	6 950	33 000	8 850
72	30	29	$0_{-0.210}$	28	38	35	0.3	56 500	72 500	8 050	38 500	8 850
	35	29	$0_{-0.210}$	28	44	41.5	0.6	62 000	85 500	8 050	37 000	10 400
80	35	29	$0_{-0.210}$	28	44	41.5	0.6	62 000	85 500	9 800	41 000	10 400
	40	32	$0_{-0.250}$	30	51	47.5	0.6	87 000	125 000	9 800	44 500	15 200
85	45	32	$0_{-0.250}$	30	55	52.5	0.6	92 000	137 000	10 400	47 000	16 700
90	40	32	$0_{-0.250}$	30	51	47.5	0.6	87 000	125 000	11 400	50 000	15 200
	50	32	$0_{-0.250}$	30	60	57	0.6	96 500	150 000	11 400	50 000	18 300
100	45	32	$0_{-0.250}$	30	55	52.5	0.6	92 000	137 000	13 000	55 500	16 700
110	50	32	$0_{-0.250}$	30	60	57	0.6	96 500	150 000	14 700	61 000	18 300

1) The tolerance of outer ring outside diameter D of NUTR2··X type and NUTR3··X type having a cylindrical outside diameter surface is JIS Class 0.

2) Smallest allowable dimension for chamfer dimension r .

Needle Roller Bearings

NTN

Allowable speed min^{-1} Grease lubrication	Number		Mass kg (approx.)	Outside dia. ¹⁾ mm D 0 -0.05
	Spherical outer ring	Cylindrical outer ring		
5 500	NUTR202/3AS	NUTR202X/3AS	0.100	35
4 700	NUTR203/3AS	NUTR203X/3AS	0.147	40
5 500	NUTR302/3AS	NUTR302X/3AS	0.160	42
4 700	NUTR303/3AS	NUTR303X/3AS	0.222	47
4 000	NUTR204/3AS	NUTR204X/3AS	0.245	52
4 000	NUTR304/3AS	NUTR304X/3AS	0.321	
3 300	NUTR205/3AS	NUTR205X/3AS	0.281	62
3 300	NUTR305/3AS	NUTR305X/3AS	0.450	
2 900	NUTR206/3AS	NUTR206X/3AS	0.466	72
2 900	NUTR306/3AS	NUTR306X/3AS	0.697	
2 400	NUTR207/3AS	NUTR207X/3AS	0.630	80
2 400	NUTR307/3AS	NUTR307X/3AS	0.840	
2 100	NUTR208/3AS	NUTR208X/3AS	0.817	85
1 900	NUTR209/3AS	NUTR209X/3AS	0.883	
2 100	NUTR308/3AS	NUTR308X/3AS	1.13	90
1 800	NUTR210/3AS	NUTR210X/3AS	0.950	
1 900	NUTR309/3AS	NUTR309X/3AS	1.40	100
1 800	NUTR310/3AS	NUTR310X/3AS	1.69	110

Needle Roller Bearings

NTN

Roller follower yoke type track roller
metric series

NUTW2 type
NUTW·X type

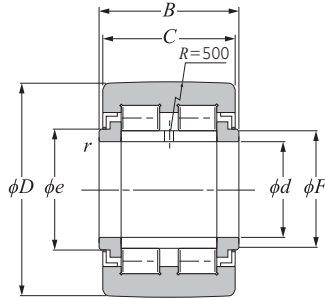

NUTW2 type

D 35–90 mm

Outside dia. ¹⁾ mm D 0 -0.05	Dimensions mm							Basic load rating		Track load capacity		Fatigue load limit N C_u
	d	B	C	e	F	r_s min ²⁾	dynamic N C_r	static C_{0r}	Spherical outer ring N	Cylindrical outer ring N		
35	15	22	0 -0.210	21	20	19	0.3	24 100	28 300	3 200	14 200	3 450
40	17	24	0 -0.210	23	22	21.5	0.3	26 000	32 000	3 850	17 100	3 900
47	20	29	0 -0.210	28	27	25.5	0.3	40 500	51 500	4 700	25 100	6 300
52	25	29	0 -0.210	28	31	30	0.3	45 000	61 500	5 550	27 700	7 500
62	30	35	0 -0.210	34	38	35	0.3	59 500	77 000	6 950	41 000	9 400
72	35	35	0 -0.210	34	44	41.5	0.6	65 000	91 000	8 050	46 000	11 100
80	40	38	0 -0.250	36	51	47.5	0.6	90 500	131 000	9 800	54 500	16 000
85	45	38	0 -0.250	36	55	52.5	0.6	95 500	144 000	10 400	58 000	17 600
90	50	38	0 -0.250	36	60	57	0.6	100 000	158 000	11 400	61 500	19 200

Needle Roller Bearings

NTN

Allowable speed min ⁻¹ Grease lubrication	Number		Mass kg (approx.)	Outside dia. ¹⁾ mm D 0 -0.05
	Spherical outer ring	Cylindrical outer ring		
5 500	NUTW202/3AS	NUTW202X/3AS	0.115	35
4 700	NUTW203/3AS	NUTW203X/3AS	0.167	40
4 000	NUTW204/3AS	NUTW204X/3AS	0.280	47
3 300	NUTW205/3AS	NUTW205X/3AS	0.322	52
2 900	NUTW206/3AS	NUTW206X/3AS	0.549	62
2 400	NUTW207/3AS	NUTW207X/3AS	0.747	72
2 100	NUTW208/3AS	NUTW208X/3AS	0.953	80
1 900	NUTW209/3AS	NUTW209X/3AS	1.03	85
1 800	NUTW210/3AS	NUTW210X/3AS	1.11	90

1) For bearings having a cylindrical outside diameter surface, code "X" is added after the bearing number. In this case, the tolerance of outer ring outside diameter D of bearing having a cylindrical is JIS Class 0. Example: NUTW203X

2) Smallest allowable dimension for chamfer dimension r .